



Figure 1 Model 350 8x6" NPS Control Valve and DFC-3220 Actuator

Model 350 Series control valves (Figure 1) are heavy-duty globe style valves featuring expanded end connections and large internal cavities. Designed to keep valve outlet velocities within practical limits, these high-capacity valves are well suited for service applications where oversized piping is used to limit flow velocities.

350 Series control valves are cage guided, single port valves that can be used for both throttling or on-off process control, and function especially well for noise reduction requirements. The standard actuator for 350 Series valves are Dyna-Flo Model DFC or DFO linear actuators (spring return diaphragm style), Model DFLP pneumatic piston actuators are also available.

Model 350 Series control valves are manufactured to a high level of quality specifications to ensure superior performance and customer satisfaction.

Features

Sour Service Capability

Available in standard configurations that comply with NACE MR0175/ISO 15156.

Versatility

A wide range of trim options including Low Noise and Anti-Cavitation make the 350 our most versatile control valve. Trims are also interchangeable between full-sized and restricted-capacity to better match variable flow demands.

Piping Efficiency

The expanded end connections of the 350 Series control valves can eliminate the need for line swages and accommodate oversized pipe arrangements.

Noise Reduction Capabilities

350 Series control valves offer a large selection of Low-Noise trim options that can reduce noise between 18 dbA and 40 dbA depending on configurations.

Field Service Friendly

No special tools are required to change or inspect trim. Top access makes in-line service easy.

Pressure Drop Capabilities

Model 350 control valves can shut off against inlet pressures equal to the ASME B16.34 rating.

Industrial High Quality External Coatings

Our standard industrial high quality external coatings provide long lasting resistance to the harshest environments.

Emissions Reducing Packing

Help prevent the loss of process media and reduce packing maintenance with the use of Dyna-Flo's Live Loaded PTFE, graphite, and KALREZ[®] packing systems.

Specifications

Configurations

The Model 350/351 control valve is a high capacity single port, globe style valve with a bolted type bonnet. The standard valve plug action is push down to close. Refer to Table 1.

PTFE Seat and Metal Seat Available.

Consult your Dyna-Flo sales office for other available configurations.

Sizes and Connection Styles (Refer to Table 1)

Model:	350 & 351
Size:	8x6" / 10x8" / 12x6" / 12x8" NPS (200x150 / 250x200 / 300x150 / 300x200 DN)
Body:	Globe
Rating:	ASME 150 / 300 / 600 / 900
Connection:	RF / RTJ / BWE (BWE for 8x6" Only)

Maximum Inlet Pressures and Temperatures

Flanged valves consistent with ASME Class 150, 300, 600 and 900 rating as per ASME B16.34, unless limited.

Maximum Pressure Drops

Maximum pressure drop is the same as maximum inlet pressure unless restricted by the following:

- Standard Valve Trim: Figures 10A - 10D.
- Anti-Cavitation Trim: Figures 10A - 10D.
- Low-Noise Valve Trim: Figures 10A - 10D.

Characteristic and Flow Direction

- Equal Percentage (Standard) - Flow Down
- Quick Opening - Flow Down
- Linear - Flow Down
- Low-Noise III A1 (Linear) - Flow Up
- Anti-Cavitation 1-Stage (Linear) - Flow Down
- Anti-Cavitation 2-Stage (Linear) - Flow Down

Dimensions

Valve and Actuator Outline Dimension Diagram: Refer to Figure 2.

Valve and Actuator Assembly Dimensions: Refer to Tables 7 to 9.

Approximate Valve Body and Actuator Weights

Refer to Table 6.

Materials

Body and bonnet material options include:

LCC (A350-LF2 optional* bonnet material)

WCC (A350-LF2 optional* bonnet material)

WC9 (A182-F22 optional* bonnet material)

CF8M (A182-F316 optional* bonnet material)

***NOTE:** Dyna-Flo reserves the right to substitute a cast material with the forged bar equivalent in the event a casting is not available.

Refer to Figures for valve construction material temperature limitations. Refer to Tables 11 - 12 for trim selections.

Control Valve Cross-Sections

Refer to Figures 3 to 9.

Port Diameters and Maximum Valve Plug Travel

Refer to Tables 3 to 5.

Packing Type and Examples

The Standard packing is PTFE V-ring. Live-loaded low emission, graphite, KALREZ[®] and other packing arrangements are available. Refer to Figure 9.

Maximum Valve Sizing Coefficients

For standard coefficients at maximum travel, refer to Table 19 to 24. For full list of coefficients, contact Dyna-Flo.

Service Application

Refer to Tables 11, 12 & 14.

For more information and other options contact your Dyna-Flo sales office.

Table 1

Available Valve Configurations and Shut-Off Class

Valve Model	Characteristic	Valve Size	ASME Class	Valve Seat	Shut-Off Class (in accordance with ANSI / FCI 70.2)
350	Equal Percentage Linear Quick Opening Low-Noise III A1	All	150 / 300 / 600	Metal	IV (Standard)
					V ⁽¹⁾ (Optional)
		PTFE		V (Standard)	
	Equal Percentage Linear Quick Opening	8x6" & 12x8" NPS (200x150 & 300x200 DN)	900	Metal	IV (Standard)
					V ⁽¹⁾ (Optional)
		PTFE		V ⁽¹⁾ (Standard)	
	Anti-Cavitation 1-Stage	All	150 / 300 / 600	Metal	V ⁽¹⁾ (Standard)
		8x6" & 12x8" NPS (200x150 & 300x200 DN)	900		
Anti-Cavitation 2-Stage	All	150 / 300 / 600	Metal	V ⁽¹⁾ (Standard)	
	8x6" & 12x8" NPS (200x150 & 300x200 DN)	900			
351	Equal Percentage Linear Quick Opening Low-Noise III A1	All	150 / 300 / 600	Metal	II (Standard)
					III (Optional)
					IV ⁽²⁾ (Optional)
	Equal Percentage Linear Quick Opening	8x6" & 12x8" NPS (200x150 & 300x200 DN)	900	Metal	II (Standard)
III (Optional)					
IV ⁽²⁾ (Optional)					
NOTES:		(1) - Class V shut-off requires spring-loaded seal ring, radius-seat plug, and wide-bevel seat ring. Not available for 8 inch port quick opening trim. Not available with S31600 plug and seat ring.			
		(2) - Class IV shut-off requires multiple graphite piston rings.			

Table 2

Available Valve Configurations for Class VI Shut-Off (in accordance with ANSI/FCI 70.2 and IEC 60534-4)

Valve Model	Port Size Inch	Valve Seat	Minimum Seat Load
350 Refer to Tables 11 & 12 for Trim options	$\geq 3.4375 \leq 7$	Metal ⁽¹⁾	300 lbs./lineal inch
	$\geq 3.4375 \leq 7$	PTFE	Consult Dyna-Flo
NOTE: (1) - Class VI shut-off requires a spring-loaded seal ring, radius-seat plug, and wide-bevel seat ring.			

Table 3

**Standard Valves
Sizes, Port Diameters, Plug Travel, Stem / Yoke Boss Diameters and Characteristic**

Valve Size	Port Diameter		Max Valve Plug Travel		Standard Yoke Boss Diameter (YBD)				Characteristic
	Inch	mm	Inch	mm	Stem Diameter		YBD		
					Inch	mm	Inch	mm	
8x6" NPS 12x6" NPS (200x150 DN 300x150 DN)	7	177.8	2	50.8	3/4 ⁽¹⁾	19.1 ⁽¹⁾	3-9/16 ⁽¹⁾	90.5 ⁽¹⁾	Equal Percentage Quick Opening Linear
					1	25.4	5	127	
					1-1/4	31.8	5H	127H	
10x8" NPS (250x200 DN)	8	203.2	3	76.2	3/4 ⁽¹⁾	19.1 ⁽¹⁾	3-9/16 ⁽¹⁾	90.5 ⁽¹⁾	Equal Percentage Quick Opening Linear
					1	25.4	5	127	
					1-1/4	31.8	5H	127H	
12x8" NPS ⁽²⁾ (300x200 DN) ⁽²⁾	8	203.2	3	76.2	3/4 ⁽¹⁾	19.1 ⁽¹⁾	3-9/16 ⁽¹⁾	90.5 ⁽¹⁾	Equal Percentage Quick Opening Linear
					1	25.4	5	127	
					1-1/4	31.8	5H	127H	

NOTES: (1) - Standard option.
(2) - Bonnet spacer required.

Table 4

**Low-Noise Valves
Sizes, Port Diameters, Plug Travel, Stem / Yoke Boss Diameters**

Valve Size	Port Diameter		Max Valve Plug Travel		Standard Yoke Boss Diameter (YBD)				Characteristic
	Inch	mm	Inch	mm	Stem Diameter		YBD		
					Inch	mm	Inch	mm	
8x6" NPS (200x150 DN)	7	177.8	3	76.2	3/4 ⁽¹⁾	19.1 ⁽¹⁾	3-9/16 ⁽¹⁾	90.5 ⁽¹⁾	Low-Noise III
					1	25.4	5	127	
					1-1/4	31.8	5H	127H	
	4	101.6	3/4 ⁽¹⁾	19.1 ⁽¹⁾	3-9/16 ⁽¹⁾	90.5 ⁽¹⁾	Low-Noise III		
			1	25.4	5	127			
			1-1/4	31.8	5H	127H			
5-3/8 ⁽²⁾	136.5 ⁽²⁾	5 ⁽²⁾	127.0 ⁽²⁾	3/4 ⁽¹⁾	19.1 ⁽¹⁾	3-9/16 ⁽¹⁾	90.5 ⁽¹⁾		
				1	25.4	5	127		
				1-1/4	31.8	5H	127H		
12x6" NPS ⁽²⁾ (300x150 DN) ⁽²⁾	5-3/8	136.5	6-1/2	165.1	3/4 ⁽¹⁾	19.1 ⁽¹⁾	3-9/16 ⁽¹⁾	90.5 ⁽¹⁾	Low-Noise III
					1	25.4	5	127	
					1-1/4	31.8	5H	127H	
10x8 (250x200 DN)	8	203.2	6	152.4	3/4 ⁽¹⁾	19.1 ⁽¹⁾	3-9/16 ⁽¹⁾	90.5 ⁽¹⁾	Low-Noise III
					1	25.4	5	127	
					1-1/4	31.8	5	127	
	7	177.8	6	152.4	3/4 ⁽¹⁾	19.1 ⁽¹⁾	3-9/16 ⁽¹⁾	90.5 ⁽¹⁾	
					1	25.4	5	127	
1-1/4	31.8	5H	127H						
12x8" NPS ⁽²⁾ (300x200 DN) ⁽²⁾	8	203.2	6	152.4	3/4 ⁽¹⁾	19.1 ⁽¹⁾	3-9/16 ⁽¹⁾	90.5 ⁽¹⁾	Low-Noise III
					1	25.4	5	127	
	7	177.8			1-1/4	31.8	5H	127H	

NOTES: (1) - Standard option.
(2) - Bonnet spacer required.

Table 5

Anti-Cavitation Valves Sizes, Port Diameters, Plug Travel, Stem / Yoke Boss Diameter

Valve Size	Port Diameter		Max Valve Plug Travel		Standard Yoke Boss Diameter (YBD)				Characteristic
	Inch	mm	Inch	mm	Stem Diameter		YBD		
					Inch	mm	Inch	mm	
8x6" NPS (200x150 DN)	5-3/8	136.5	5	127.0	3/4 ⁽¹⁾	19.1 ⁽¹⁾	3-9/16 ⁽¹⁾	90.5 ⁽¹⁾	Anti-Cavitation 2-Stage
					1	25.4	5	127	
					1-1/4	31.8	5	127	
8x6" NPS 12x6" NPS (200x150 DN 300x150 DN)	7	177.8	2	50.8	1 ⁽¹⁾	25.4 ⁽¹⁾	5 ⁽¹⁾	127 ⁽¹⁾	Anti-Cavitation 1-Stage
					1-1/4	31.8	5	127	
			2-1/4	57.2	1 ⁽¹⁾	25.4 ⁽¹⁾	5 ⁽¹⁾	127 ⁽¹⁾	Anti-Cavitation 1-Stage Extended Travel
					1-1/4	31.8	5	127	
12x6" NPS (300x150 DN)	5-3/8	136.5	6	152.4	3/4 ⁽¹⁾	19.1 ⁽¹⁾	3-9/16 ⁽¹⁾	90.5 ⁽¹⁾	Anti-Cavitation 2-Stage
					1	25.4	5	127	
					1-1/4	31.8	5	127	
10x8" NPS 12x8" NPS (250x200 DN 300x200 DN)	8	203.2	3	76.2	1 ⁽¹⁾	25.4 ⁽¹⁾	5 ⁽¹⁾	127 ⁽¹⁾	Anti-Cavitation 1-Stage
					1-1/4	31.8	5	127	
			3-3/8	85.7	1 ⁽¹⁾	25.4 ⁽¹⁾	5 ⁽¹⁾	127 ⁽¹⁾	Anti-Cavitation 1-Stage Extended Travel
					1-1/4	31.8	5	127	
12x8" NPS (300x200 DN)	7	177.8	6	152.4	3/4 ⁽¹⁾	19.1 ⁽¹⁾	3-9/16 ⁽¹⁾	90.5 ⁽¹⁾	Anti-Cavitation 2-Stage
					1	25.4	5	127	
					1-1/4	31.8	5	127	

NOTES: (1) - Standard Option.

Table 6

Approximate Valve Body Weights

Valve Size	Connection	ASME Class					
		150 / 300		600		900	
		lb	Kg	lb	Kg	lb	Kg
8x6" NPS (200x150 DN)	Flanged	625	284	680	308	1,350	612
	Buttweld	n/a	n/a	600	272	1,000	454
10x8" NPS (250x200 DN)	Flanged	1,250	567	1,640	744	n/a	n/a
12x6" NPS (300x150 DN)	Flanged	1,102	500	1,590	721	n/a	n/a
12x8" NPS (300x200 DN)	Flanged	1,440	653	1,890	857	3,000	1,361

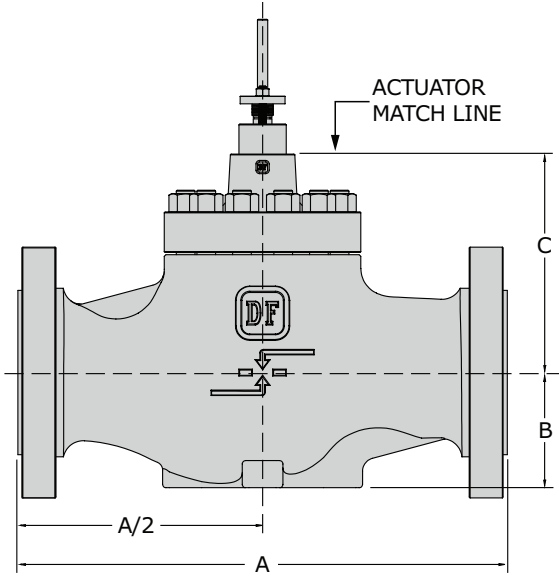

FLANGED VALVE ASSEMBLY

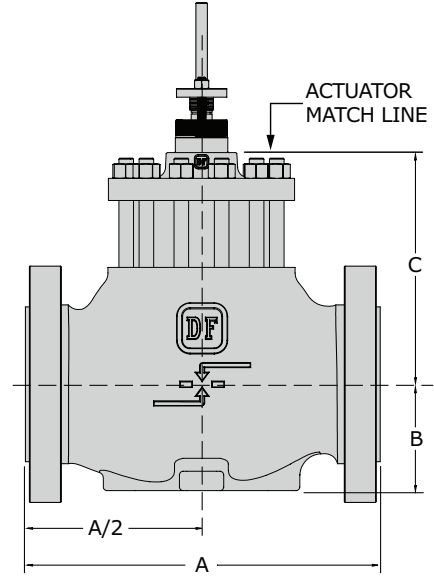

FLANGED VALVE ASSEMBLY FOR LOW-NOISE TRIM

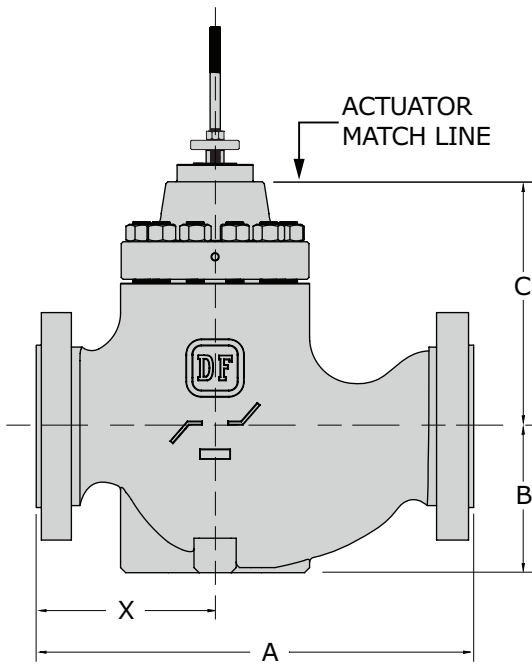

12X8" NPS (300x200 DN) FLANGED VALVE ASSEMBLY

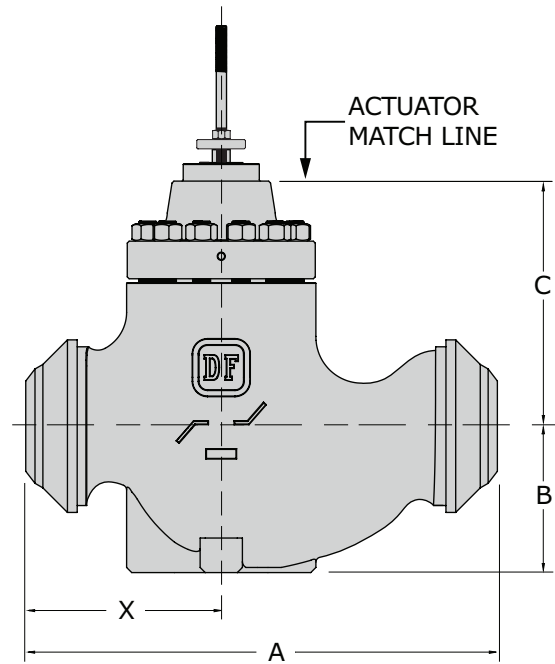

12X6" NPS (300x150 DN) BUTTWELD VALVE ASSEMBLY

Figure 2 Typical Valve Dimensional Diagrams

Table 7

Dimension C for Standard Valve Configurations
 (Refer to Figure 2)

Characteristic	Bonnet	Valve Size	Stem Diameter - inch (mm)				
			1/2 (12.7)	3/4" (19.1mm)		1" (25.4mm)	
				ASME Class 150 / 300 / 600	ASME Class 900	ASME Class 300 / 600	ASME Class 900
Equal Percentage Quick Opening Linear	Standard	8x6" NPS (200x150 DN)	11.31 (287)	11.31 (287)	16.12 (409)	13.06 (332)	18.25 (464)
		10x8" NPS (250x200 DN)	-	14.75 (375)	-	-	-
		12x6" NPS (300x150 DN)	14.00 (356)	14.00 (356)	-	15.75 (400)	-
		12x8" NPS (300x200 DN)	-	16.19 (411)	23.00 (584)	-	23.94 (608)
	Style 1 Extension	8x6" NPS (200x150 DN)	-	15.50 (394)	-	18.25 (464)	-
		10x8" NPS (250x200 DN)	-	16.56 (421)	-	17.69 (449)	-
		12x6" NPS (300x150 DN)	-	18.19 (462)	-	20.94 (532)	-
		12x8" NPS (300x200 DN)	-	18.00 (457)	-	19.12 (486)	-
	Style 2 Extension	8x6" NPS (200x150 DN)	-	22.81 (579)	-	-	-
		10x8" NPS (250x200 DN)	-	24.44 (621)	-	-	-
		12x6" NPS (300x150 DN)	-	25.50 (648)	-	-	-
		12x8" NPS (300x200 DN)	-	-	-	-	-
Anti-Cavitation	Standard	8x6" NPS (200x150 DN)	15.88 (403)	15.88 (403)	-	-	-
		10x8" NPS (250x200 DN) 1-Stage	-	14.75 (375)	-	16.75 (425)	-
		10x8" NPS (250x200 DN) 2-Stage	-	20.12 (511)	-	22.06 (560)	-
		12x6" NPS (300x150 DN)	18.88 (480)	18.88 (480)	-	-	-
		12x8" NPS (300x200 DN)	-	-	-	-	-
Low-Noise	Standard	8x6" NPS (200x150 DN)	11.31 (287)	15.69 (399)	16.12 (409)	17.44 (443)	18.25 (464)
		10x8" NPS (250x200 DN)	-	19.83 (504)	-	-	-
		12x6" NPS (300x150 DN)	14.00 (356)	19.81 (503)	-	21.56 (548)	-
		12x8" NPS (300x200 DN)	-	-	-	-	-

Table 8

Valve Body Dimensions
(Refer to Figure 2 on Page 6) (For 'C' Dimensions refer to Table 7)

Valve Size	Dimension A - inch (mm)								Dimension B - inch (mm)	
	ASME Class 150	ASME Class 300		ASME Class 600		ASME Class 900			ASME Class 150 / 300/ 600	ASME Class 900
	RF	RF	RTJ	RF / BWE	RTJ	RF	RTJ	BWE		
8x6" NPS (200x150 DN)	21.38 (543)	22.38 (568)	23.00 (584)	24.00 (610)	24.12 (613)	36.00 (914)	36.12 (917)	38.25 (972)	7.19 (183)	7.81 (198)
10x8" NPS (250x200 DN)	26.50 (673)	27.88 (708)	28.50 (724)	29.62 (752)	29.75 (756)	-	-	-	10.81 (275)	-
12x6" NPS (300x150 DN)	29.00 (737)	30.50 (775)	31.12 (791)	32.25 (819)	32.38 (822)	-	-	-	10.00 (254)	-
12x8" NPS (300x200 DN)	29.00 (737)	30.50 (775)	31.12 (791)	32.25 (819)	32.38 (822)	35.50 (902)	35.62 (905)	37.50 (953)	14.00 (356)	14.00 (356)

NOTES: RF = Raised Face / RTJ = Ring Type Joint / BWE = Buttweild

Table 9

Dimension X for 12x8" NPS (300x200 DN) Valves
(Refer to Figure 2 on Page 6) (For 'C' Dimensions refer to Table 7)

Valve Size	Dimension X - inch (mm)							
	ASME Class 150	ASME Class 300		ASME Class 600		ASME Class 900		
	RF	RF	RTJ	RF / BWE	RTJ	RF	RTJ	BWE
12x8" NPS (300x200 DN)	11.50 (292)	12.25 (311)	12.56 (319)	13.12 (333)	13.18 (335)	15.63 (397)	15.69 (398)	16.63 (422)

NOTES: RF = Raised Face / RTJ = Ring Type Joint / BWE = Buttweild

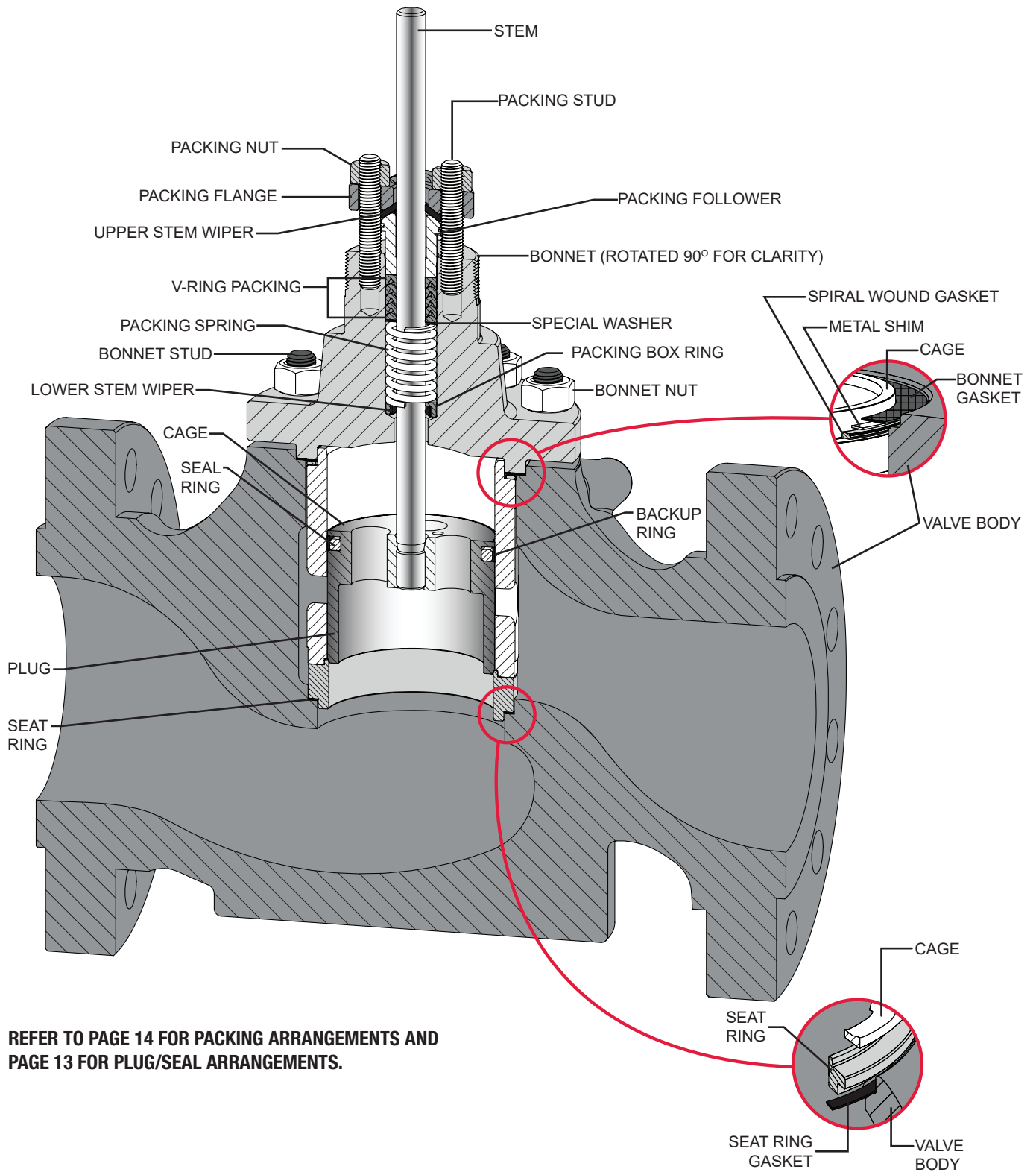

REFER TO PAGE 14 FOR PACKING ARRANGEMENTS AND
PAGE 13 FOR PLUG/SEAL ARRANGEMENTS.

Figure 3 Standard Valve Assembly - 7 Inch (177.8mm) Port and Under

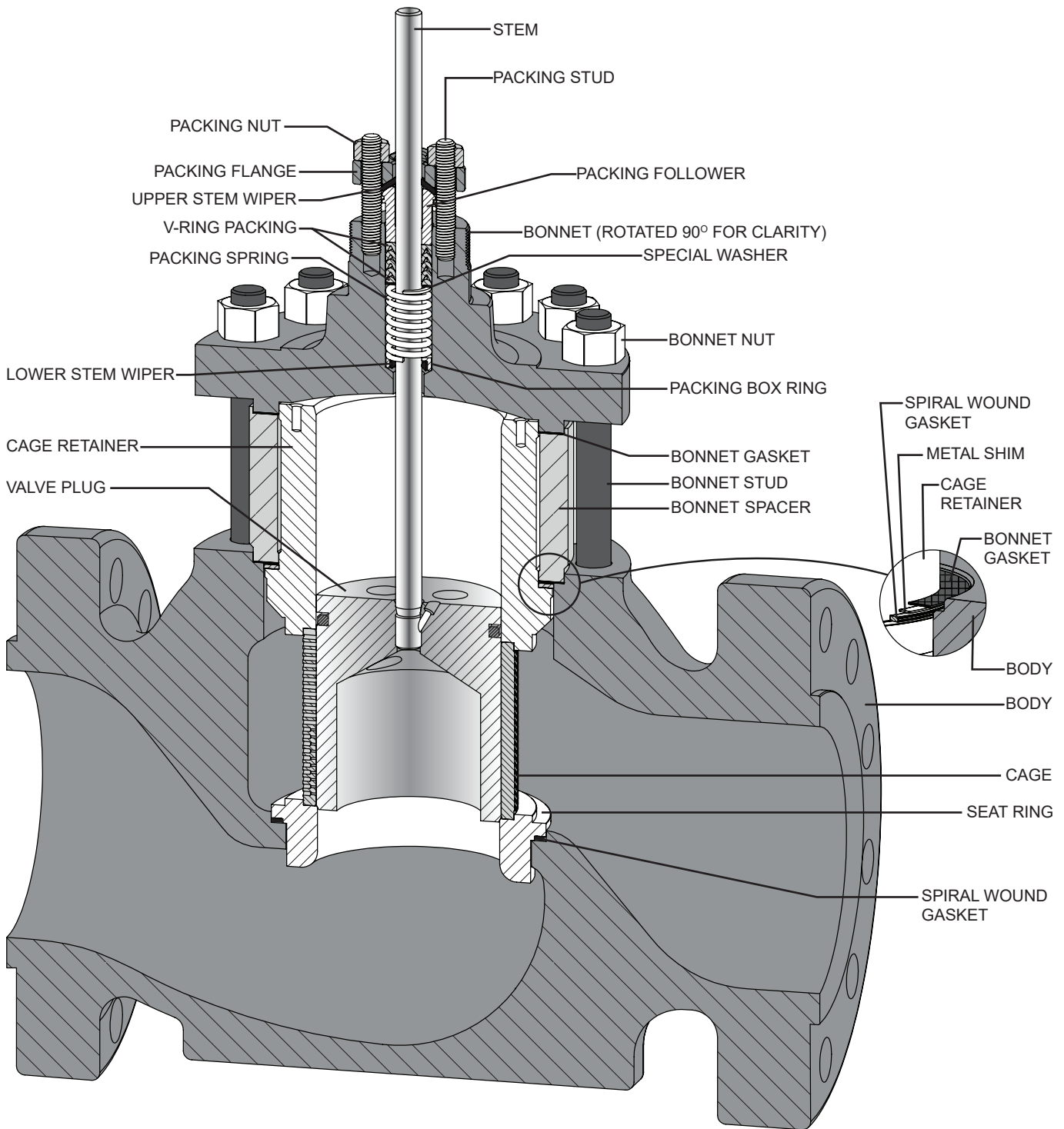

REFER TO PAGE 14 FOR PACKING ARRANGEMENTS AND
PAGE 13 FOR PLUG/SEAL ARRANGEMENTS.

Figure 4 Standard Low-Noise Valve Assembly - 7 Inch (177.8mm) Port and Under

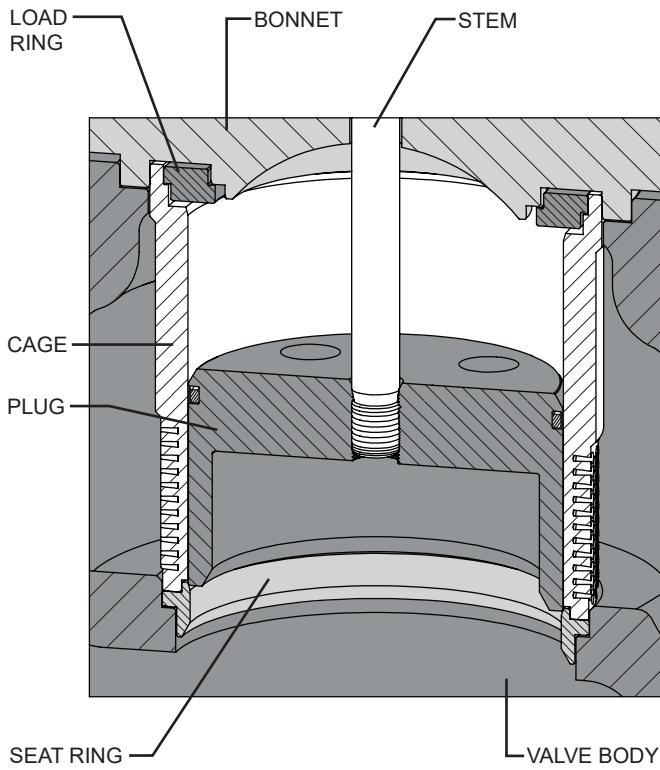

Figure 5 10x8" & 12x8" NPS (250x200 & 300x200 DN) Anti-Cavitation Valve Assembly with Load Ring

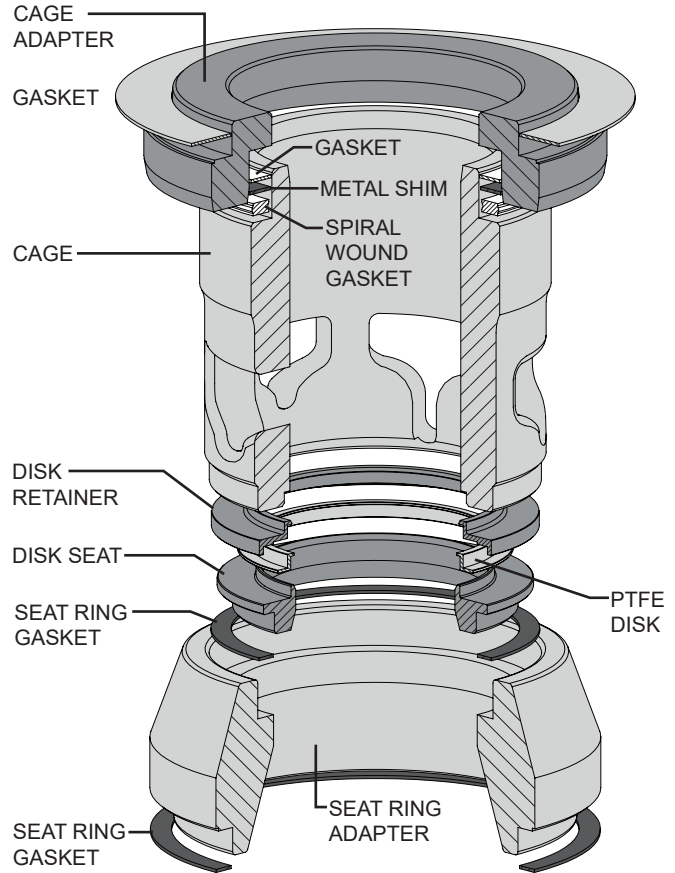

Figure 6 Reduced Trim Assembly Diagram

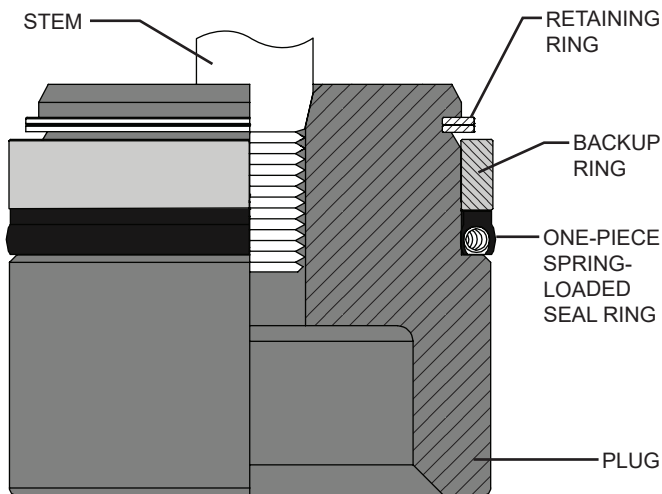

Figure 7 Spring-Loaded Plug Seal Arrangement

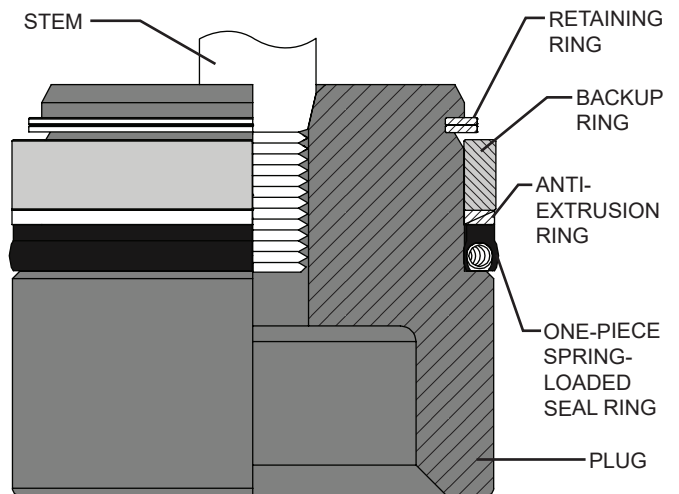

Figure 8 Spring-Loaded Plug Seal with Anti-Extrusion Ring

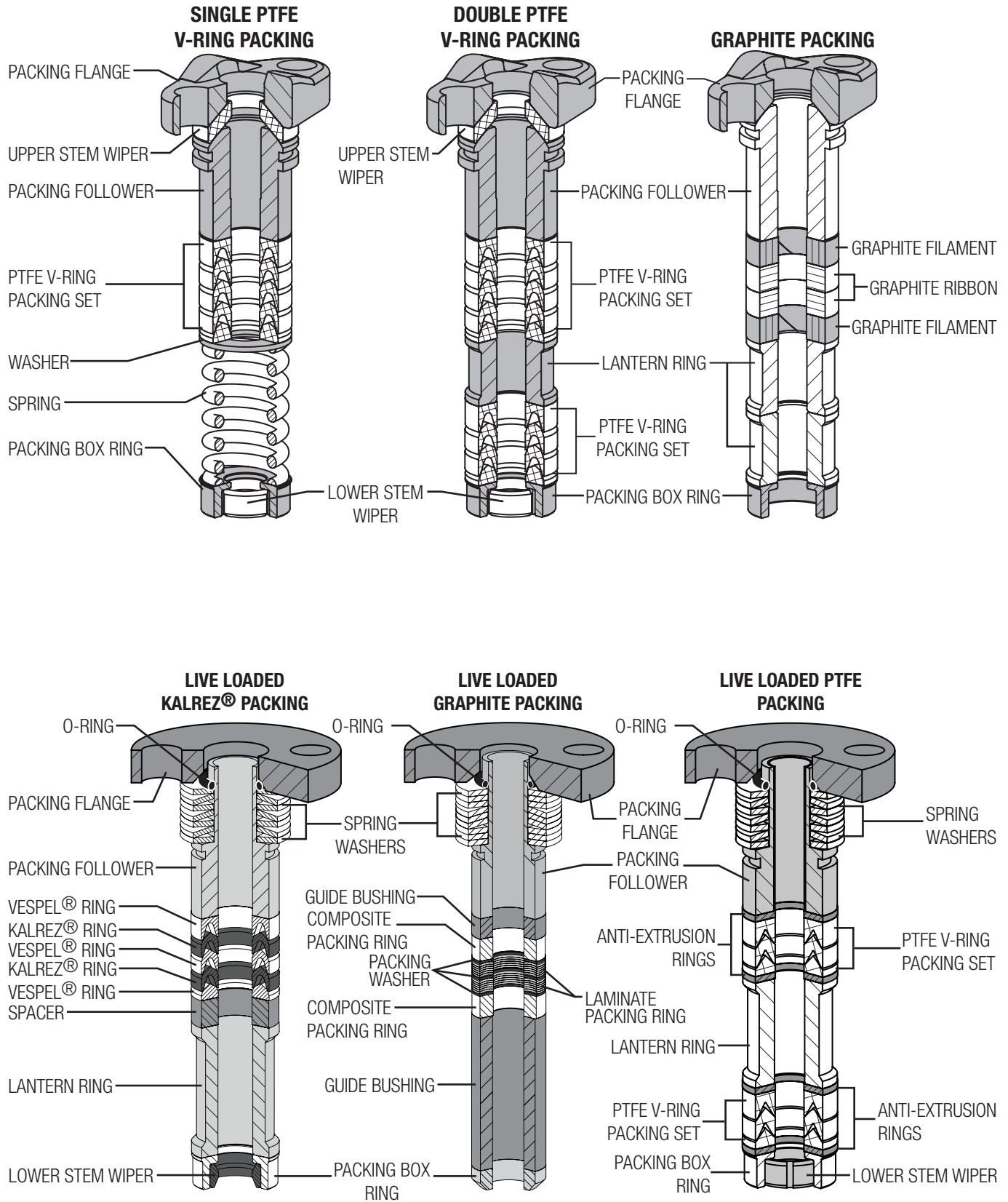

Figure 9 Typical Packing Arrangements

Table 10

Common Valve Parts Typical Construction Materials and Temperature Limitations

Part	Material	Temperature Limitations				
		Min. °F	Max. °F	Min. °C	Max. °C	
Valve Stem	S20910	NLF ⁽⁴⁾	NLF ⁽⁴⁾	NLF ⁽⁴⁾	NLF ⁽⁴⁾	
Load Ring (10x8" & 12x8" Valves Only)	S17400	-150	600	-102	316	
Two-Piece Valve Plug Seal ⁽¹⁾	Backup Ring	Fluoroelastomer (Viton [®]) ⁽⁷⁾	0	400	-18	204
		Ethylene Propylene ⁽⁸⁾	-40	450	-40	232
	Seal Ring	Carbon-Filled PTFE (Standard)	-100	450	-73	232
Spring-Loaded (Three-Piece) Valve Plug Seal ⁽²⁾⁽³⁾	Backup Ring ⁽³⁾	S31600/S31603 Dual Grade	NLF ⁽⁴⁾	NLF ⁽⁴⁾	NLF ⁽⁴⁾	NLF ⁽⁴⁾
	Seal Ring	Carbon-Filled PTFE / Elgiloy	-100	450	-73	232
	Retaining Ring ⁽³⁾	S31600	NLF ⁽⁴⁾	NLF ⁽⁴⁾	NLF ⁽⁴⁾	NLF ⁽⁴⁾
Spring-Loaded (Three-Piece) Valve Plug Seal with Anti-Extrusion Rings ⁽³⁾	Anti-Extrusion Ring ⁽³⁾	PolyEtherEtherKetone (PEEK)	NLF ⁽⁴⁾	NLF ⁽⁴⁾	NLF ⁽⁴⁾	NLF ⁽⁴⁾
	Backup Ring ⁽³⁾	S31600/S31603 Dual Grade	NLF ⁽⁴⁾	NLF ⁽⁴⁾	NLF ⁽⁴⁾	NLF ⁽⁴⁾
	Seal Ring	Carbon-Filled PTFE / Elgiloy	-100	600	-73	319
	Retaining Ring ⁽³⁾	S31600	NLF ⁽⁴⁾	NLF ⁽⁴⁾	NLF ⁽⁴⁾	NLF ⁽⁴⁾
Seat Ring / Bonnet / Cage Gaskets	S31600 / Graphite	NLF ⁽⁴⁾	NLF ⁽⁴⁾	NLF ⁽⁴⁾	NLF ⁽⁴⁾	
Spiral Wound Gaskets	S30400 / Graphite	-50	650	-46	343	
	N06600 / Graphite (High Temp.)	NLF ⁽⁴⁾	NLF ⁽⁴⁾	NLF ⁽⁴⁾	NLF ⁽⁴⁾	
Piston Ring (Model 351)	Graphite	-50 ⁽⁵⁾	1100	-46	593 ⁽⁵⁾	
Shim	S30400	NLF ⁽⁴⁾	NLF ⁽⁴⁾	NLF ⁽⁴⁾	NLF ⁽⁴⁾	
Disk	PTFE	-100	400	-73	204	
Disk Seat	S31600/S31603 Dual Grade	NLF ⁽⁴⁾	NLF ⁽⁴⁾	NLF ⁽⁴⁾	NLF ⁽⁴⁾	
Disk Retainer	S31600/S31603 Dual Grade	NLF ⁽⁴⁾	NLF ⁽⁴⁾	NLF ⁽⁴⁾	NLF ⁽⁴⁾	
Packing	PTFE V-Ring	-40	450	-40	232	
	Graphite (Ribbon/Filament)	-325	1000 ⁽⁶⁾	-198	537 ⁽⁶⁾	

NOTES:

- (1) Standard for 350 valves sizes 8x6" & 12x6" NPS (200x150 & 300x150 DN) except those with Anti-Cavitation trim.
- (2) Standard for 10x8" & 12x8" NPS (250x200 & 300x200 DN) valves and valves with Anti-Cavitation trim. Optional for 8x6" to 12x6" valves with trim other than Anti-Cavitation.
- (3) Do not use with 7" (178mm) large or greater port sizes, 8" NPS (200 DN) valve assemblies utilize a seal ring only. Anti-extrusion rings will allow for a maximum temperature limitation of 600°F (316°C).
- (4) NLF - This Material is Not A Limiting Factor. For the temperature limitation refer to the valve body material temperature limit.
- (5) Limited because of thermal expansion differential between the piston ring and the cage.
- (6) Oxidizing service limited to 700°F (371°C).
- (7) Recommended for high-temperature air, hydrocarbons, and some chemicals/solvents. Not recommended for water above 180°F (82°C). Do not use with ammonia or steam.
- (8) Recommended for hot water and steam. May be used with most fire-resistant hydraulic oils. Do not use with petroleum-based fluids and other hydrocarbons.

Table 11

Trim Options (Refer to Figures 10 - 14 for Pressure / Temperature Limits)

Trim Spec	Valve Plug	Stem	Cage	Seat Ring	Service
D1	S41600 HT	S20910	S17400 H900	S41600 HT	Standard / Non-corrosive / High Temp
D2	S31600 ⁽²⁾ / Alloy 6 Hard Faced Seat	S20910	S17400 DH1150 ⁽¹⁾	S31600 ⁽²⁾ / Alloy 6 Hard Faced Seat	Corrosive / NACE High Temperature
D4	S31600 ⁽²⁾	S20910	S17400 H900	S31600 ⁽²⁾	General / Mild Corrosive
D5	S41600 HT	S20910	S17400 H900	S31600 ⁽²⁾ / PTFE	Standard / Non-corrosive / Tight Shut off
D6	S31600 ⁽²⁾ / Alloy 6 Hard Faced Seat & Guide	S20910	S17400 H900	S31600 ⁽²⁾ / Alloy 6 Hard Faced Seat	Standard / Mild Corrosive / Mild Erosive
D7	S31600 ⁽²⁾ / Alloy 6 Hard Faced Seat & Guide	S20910	S17400 DH1150	S31600 ⁽²⁾ / Alloy 6 Hard Faced Seat	Corrosive / High Temp / NACE / Mild Erosive
D8	S31600 ⁽²⁾	S20910	S17400 DH1150 ⁽¹⁾	S31600 ⁽²⁾	NACE / Corrosive
D9	S31600 ⁽²⁾	S20910	S17400 DH1150 ⁽¹⁾	S31600 ⁽²⁾ / PTFE	NACE / Corrosive / Tight Shut off
DL	S42000 HT	S20910	S17400 H900	S17400 H900	Anti-Cavitation
DJ	S31600 ⁽²⁾	S20910	S31600 ² / ENC	S31600 ⁽²⁾	NACE
DT	S31600 ⁽²⁾	S20910	S31600 ² / ENC	S31600 ⁽²⁾ / PTFE	NACE
DE	S31600 ⁽²⁾ / Alloy 6 Hard Faced Seat & Guide	S20910	S31600 ² / ENC	S31600 ⁽²⁾ / Alloy 6 Hard Faced Seat	NACE
DN	S31600 ⁽²⁾ / Alloy 6 Hard Faced Seat & Guide	S20910	S31600 ⁽²⁾ / ENC	S31600 ⁽²⁾	NACE Class VI Soft Metal
DR	S31600 ⁽²⁾ / Alloy 6 Hard Faced Seat & Guide	S20910	S17400 DH1150	S31600 ⁽²⁾	NACE Class VI Soft Metal

NOTES:

- (1) - S31600 (ENC)* available by special request (*Electroless Nickel Coating).
- (2) - All S31600 barstock is dual grade S31600/S31603 (316/316L).

Table 12

Model 350 Class VI Shut-Off Trim Options (Refer to Figures 10 - 12 for Pressure / Temperature Limits)

Valve Plug	Stem	Cage	Seat Ring	Seal Ring	Temperature Limit
S41600 HT	S20910	S17400 H900	S31600 ⁽²⁾	PTFE/R30003	-20°F to 150°F (-29°C to 66°C)
S41600 HT	S20910	S17400 H900	S31600 ⁽²⁾ / PTFE	PTFE/R30003	-20°F to 150°F (-29°C to 66°C)
S31600 ⁽²⁾	S20910	S31600 ² / ENC	S31600 ⁽²⁾ / PTFE	PTFE/R30003	-20°F to 150°F (-29°C to 66°C)
S31600 ⁽²⁾ / Alloy 6 Hard Faced Seat	S20910	S31600 ² / ENC	S31600 ⁽²⁾	PTFE/R30003	-50°F to 150°F (-46°C to 66°C)

NOTES:

- (1) - S31600 (ENC)* available by special request (*Electroless Nickel Coating).
- (2) - All S31600 barstock is dual grade S31600/S31603 (316/316L).

Table 13

Body to Bonnet Bolting Temperature Limitations

Body Material	ASME Class	Bolt/Nut Material	Temperature Limitations			
			Min. °F	Max. °F	Min. °C	Max. °C
LCC	150/300/600	B7/2H ⁽¹⁾⁽²⁾	-50	650	-46	343
		B7M/2HM ⁽³⁾	-50	650	-46	343
WCC/WC9	150/300/600	B7/2H ⁽¹⁾⁽²⁾	-20	800	-29	427
		B7M/2HM ⁽³⁾	-20	800	-29	427
CF8M	150/300/600	B7 Fluorokote #1 / 2H Fluorokote #1 (Standard) ⁽²⁾	-50	500	-46	260
		B8M/8M ⁽²⁾	-325	800	-198	427
		B7M Fluorokote #1/ 2HM Fluorokote #1 ⁽³⁾	-50	500	-46	260

NOTES:

- (1) Standard non-NACE option.
- (2) NACE MR0175/ISO15156 Non-Exposed Bolting option (Bolting that is not directly exposed to sour environments and is not to be buried, insulated, equipped with flange protectors, or otherwise denied direct atmospheric exposure).
- (3) NACE MR0175/ISO15156 Exposed Bolting option (Bolting that will be exposed directly to the sour environment or that will be buried, insulated, equipped with flange protectors, or otherwise denied direct atmospheric exposure).

Table 14

Bonnet and Packing Selection⁽¹⁾

Bonnet Style	Packing Material	In-Body Process Temperature Limitations
Standard Bonnet: Standard for valve sizes 8x6 through 12x6.	PTFE V-Ring	0°F to 450°F (-18°C to 232°C) ⁽²⁾
	Graphite (Ribbon/Filament)	0°F to Table 10 limits (-18°C to Table 10 limits)
Style 1 Extension Bonnet: Optional for valve sizes 8x6 through 12x6. Standard for valve sizes 10x8 and 12x8.	PTFE V-Ring	-50°F to 800°F (-46°C to 427°C)
	Graphite (Ribbon/Filament)	Refer to maximum Table 10 limits
Style 2 Extension Bonnet: Optional for valve sizes 8x6 through 12x6. Optional for valve sizes 10x8 and 12x8.	PTFE V-Ring	-150°F to 800°F (-101°C to 427°C)
	Graphite (Ribbon/Filament)	Refer to maximum Table 10 limits

NOTES:

- (1) The above temperatures assume the presence of an ambient temperature outside the valve body of 70°F (21°C) with no bonnet insulation. An extension bonnet may be required when operating valves in low temperatures to prevent damage that could occur from the formation of valve stem frost. Other limiting factors, such as trim material components, will have to be considered.
- (2) Consult Dyna-Flo for temperatures above 450°F (232°C).

For temperatures above or below these standard temperatures consult Dyna-Flo.

Standard⁽¹⁾ Valve Body/Trim Option Temperature Limitations for ASME Class 150 - 600
(Refer to Figures 10 - 12 for Pressure/Temperature Limits)

Body Material	Trim Designation	Valve Size	Temperature Limitations			
			Min. °F	Max. °F	Min. °C	Max. °C
LCC	D1	8x6" NPS (200x150 DN)	-20	625	-29	329
		12x6" NPS (300x150 DN)	-20	500	-29	260
		10x8" & 12x8" NPS (250x200 & 300x200 DN)	-20	650	-29	343
	D5	8x6" & 10x8" NPS (200x150 & 250x200 DN)	-20	400	-29	204
	D6	All Sizes	-50	410	-46	210
	DJ	8x6" NPS (200x150 DN)	-50	400	-46	204
		12x6" NPS (300x150 DN)	-50	325	-46	163
		10x8" & 12x8" NPS (250x200 & 300x200 DN)	-50	600	-46	316
	CF8M	DJ / DE	All Sizes	-325	600	-198
WCC	D1	8x6" NPS (200x150 DN)	-20	600	-29	316
		12x6" NPS (300x150 DN)	-20	500	-29	260
		10x8" & 12x8" NPS (250x200 & 300x200 DN)	-20	800	-29	427
	D5	All Sizes	-20	400	-29	204
	D6	All Sizes	-20	410	-29	210
	DJ	8x6" NPS (200x150 DN)	-20	400	-29	204
		12x6" NPS (300x150 DN)	-20	345	-29	174
		10x8" & 12x8" NPS (250x200 & 300x200 DN)	-20	600	-29	316
	WC9	D1	8x6" NPS (200x150 DN)	-20	600	-29
12x6" NPS (300x150 DN)			-20	500	-29	260
10x8" & 12x8" NPS (250x200 & 300x200 DN)			-20	800	-29	427
D5		All Sizes	-20	400	-29	204
D6		All Sizes	-20	410	-29	210
DE		8x6" NPS (200x150 DN)	-20	400	-29	204
		12x6" NPS (300x150 DN)	-20	325	-29	163
		10x8" & 12x8" NPS (250x200 & 300x200 DN)	-20	650	-29	343
DJ		8x6" NPS (200x150 DN)	-20	400	-29	204
		12x6" NPS (300x150 DN)	-20	325	-29	163
		10x8" & 12x8" NPS (250x200 & 300x200 DN)	-20	600	-29	316

NOTES:

(1) - For metal trim parts only. Not to be used with Low-Noise or Anti-Cavitation trim.

Table 16

Anti-Cavitation Valve Body/Trim Option Temperature Limitations (Refer to Figures 10 - 12 for Pressure/Temperature limits)

Body Material	Trim Designation	Valve Size	Temperature Limitations			
			Min. °F	Max. °F	Min. °C	Max. °C
LCC	DL	All Sizes	-50	NLF ⁽¹⁾	-46	NLF ⁽¹⁾
CF8M	DL	8x6" NPS (200x150 DN)	-20	250	-29	121
		12x6" NPS (300x150 DN)	-20	225	-29	107
		12x8" NPS (300x200 DN) ⁽²⁾	-20	350	-29	177
WCC & WC9	DL	All Sizes	-20	NLF ⁽¹⁾	-29	NLF ⁽¹⁾
NOTES:		(1) - NLF - This Material is Not A Limiting Factor. For the temperature limitation refer to the valve body material temperature limit.				
		(2) - Available for all 12x8" NPS (300x200 DN) ASME Class ratings.				

Table 17

Low-Noise⁽¹⁾ Valve Body/Trim Option Temperature Limitations (Refer to Figures 10 - 12 for Pressure/Temperature limits)

Body Material	Trim Designation	Valve Size	Temperature Limitations				
			Min. °F	Max. °F	Min. °C	Max. °C	
CF8M	D1	8x6" NPS (200x150 DN)	-20	300	-29	149	
		10x8" NPS (250x200 DN)	-20	300	-29	149	
		12x8" NPS (300x200 DN)	-20	300	-29	149	
	D5	8x6" NPS (200x150 DN)	-20	300	-29	149	
		10x8" NPS (250x200 DN)	-20	300	-29	149	
		12x8" NPS (300x200 DN)	-20	300	-29	149	
	DE	8x6" NPS (200x150 DN)	-325	650	-198	343	
		10x8" NPS (250x200 DN)	-325	650	-198	343	
		12x8" NPS (300x200 DN)	-325	650	-198	343	
	DE 5-3/8" (136.5 mm) Port	8x6" NPS (200x150 DN)	-20	650	-29	343	
		12x6" NPS (300x150 DN)	-20	650	-29	343	
	WCC & WC9	D1	8x6" NPS (200x150 DN)	-20	800	-29	427
10x8" NPS (250x200 DN)			-20	800	-29	427	
12x8" NPS (300x200 DN)			-20	800	-29	427	
D5		8x6" NPS (200x150 DN)	-20	400	-29	204	
		10x8" NPS (250x200 DN)	-20	400	-29	204	
		12x8" NPS (300x200 DN)	-20	400	-29	204	
DE		8x6" NPS (200x150 DN)	-20	600	-29	316	
		10x8" NPS (250x200 DN)	-20	600	-29	316	
		12x8" NPS (300x200 DN)	-20	600	-29	316	
DE 5-3/8" (136.5 mm) Port		8x6" NPS (200x150 DN)	-20	400	-29	204	
		12x6" NPS (300x150 DN)	-20	350	-29	177	
NOTES:		(1) - For metal trim parts only. Not to be used with Standard or Anti-Cavitation trim.					

Notes For Trim Pressure / Temperature Charts - Refer to Figures 10 to 14.

Refer to the ASME Class Rating or the body material being used, DO NOT exceed these Pressure/Temperature Limitations even though trim limitations may be better.

1	Trim can be used to 1,440 Psi (9,900 kPa) when used with clean dry gas. When used with other process fluids, do not exceed 300 Psi (2,100 kPa).
2	Trim temperature limitations can be extended to 600°F (316°C) when used for non-oxidizing service or 500°F (260°C) with oxidizing service when using PEEK anti-extrusion rings and spring-loaded seal rings.
3	Temperatures above 450°F (232°C) require a spring-loaded seal ring and PEEK anti-extrusion rings.
4	Use trim DE instead of DJ for non-lubricating fluids (such as dry gas or steam) between 300°F (149°C) and 450°F (232°C).
5	Can be used over 300 Psi (2,100 kPa) with clean, dry gas.
6	Temperature limits can be extended down to -150°F (-101°C) with Low-Noise III style A, B, or C cages, or with style D cage that has an 18-8 SST baffle.

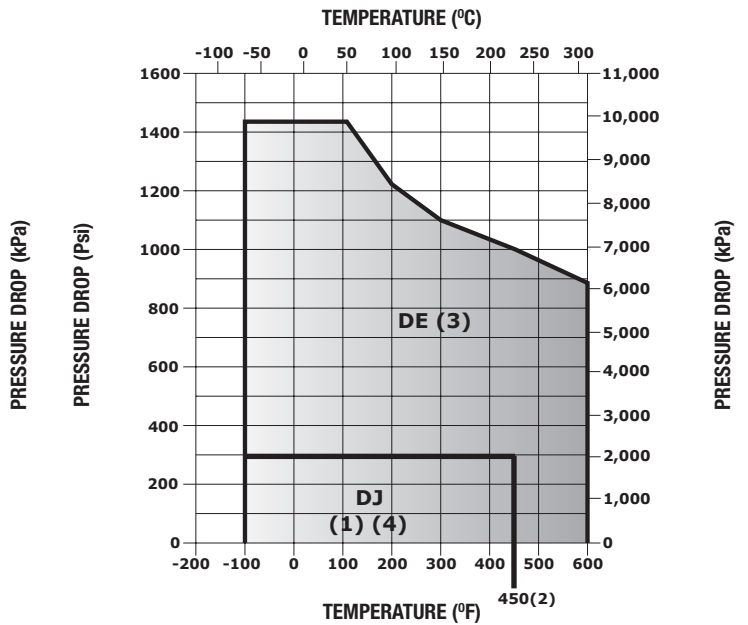
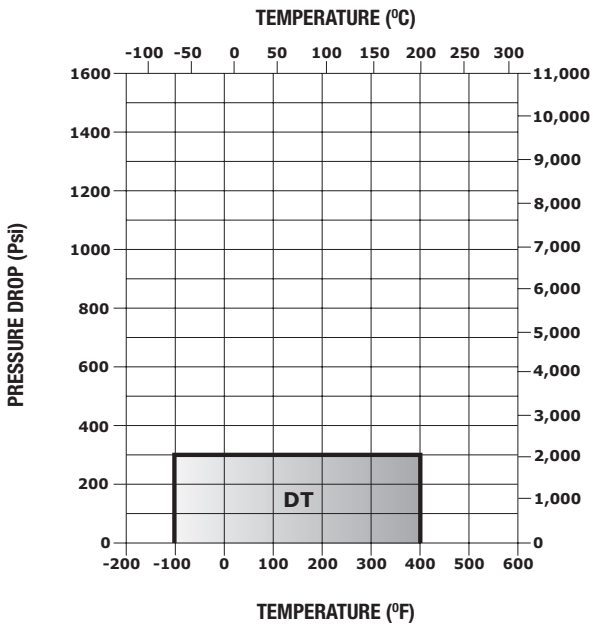
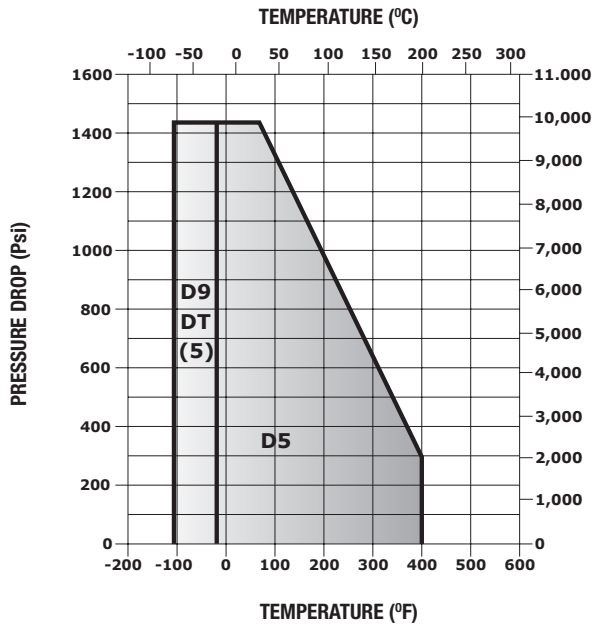
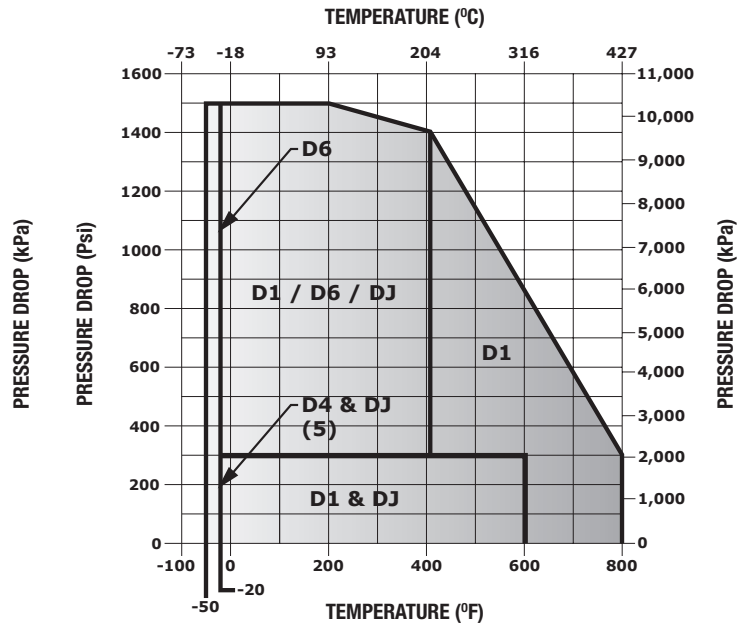

Figure 10 Typical Valve Trim Pressure and Temperature Limitations for Soft Seated Valves



TRIM D5, D9, & DT FOR PTFE SEATED ASME CLASS 600 VALVES



TRIM D1, D4, D6, & DJ WITH LCC OR WCC FOR ASME CLASS 600 VALVES

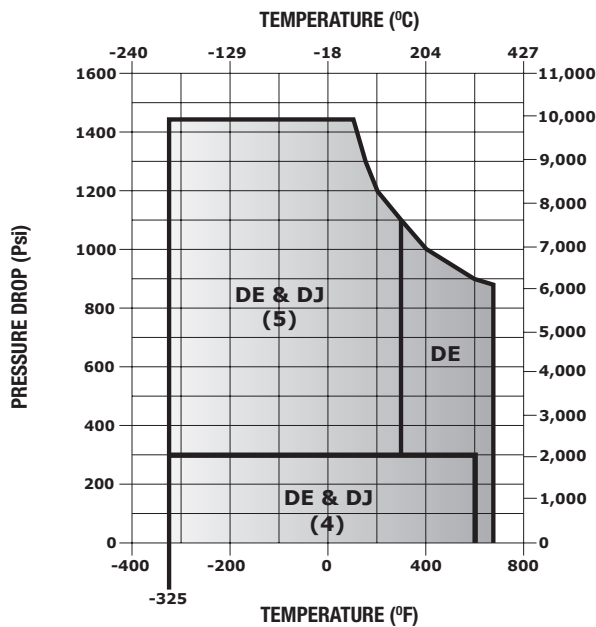

TRIM DE & DJ WITH CF8M ASME CLASS 600 VALVES

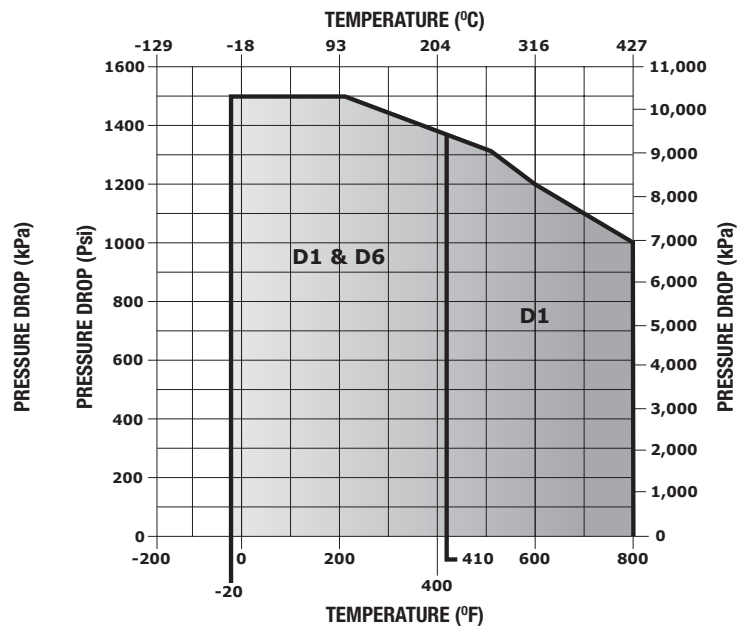

TRIM D1 & D6 WITH WC9 FOR ASME CLASS 600 VALVES

Figure 11 Typical Valve Trim Pressure and Temperature Limitations for Soft Seated Valves Continued

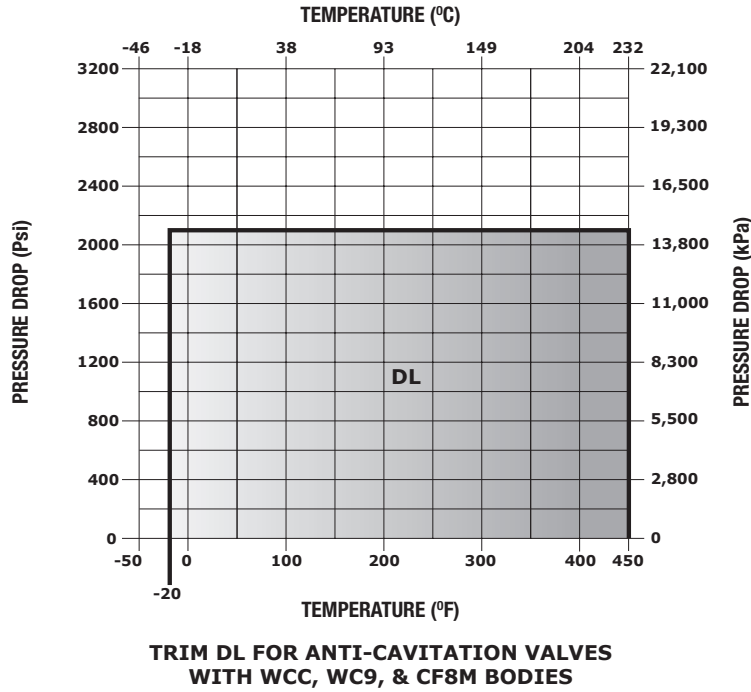

Figure 12 Typical Valve Trim Pressure and Temperature Limitations for Anti-Cavitation Trim

Table 19

Equal Percentage Characteristic - Maximum Sizing Coefficients

Valve Size	Port Inches (mm)	Travel Inches (mm)	ASME Class	Coefficient	Percentage of Valve Travel
					100%
8x6" NPS (200x150 DN)	7 (177.8)	2 (50.8)	150-600	C _v	508
			900	C _v	477
10x8" NPS (250x200 DN)	8 (203.2)	3 (76.2)	150-600	C _v	924
12x6" NPS (300x150 DN)	7 (177.8)	2 (50.8)	150-600	C _v	565
12x8" NPS (300x200 DN)	8 (203.2)	3 (76.2)	150-600	C _v	1090
			900	C _v	1090

NOTE: For the complete list of sizing coefficients, contact Dyna-FLo.

Table 20

Linear Characteristic - Maximum Sizing Coefficients

Valve Size	Port Inches (mm)	Travel Inches (mm)	ASME Class	Coefficient	Percentage of Valve Travel
					100%
8x6" NPS (200x150 DN)	7 (177.8)	2 (50.8)	150-600	C _v	617
			900	C _v	644
10x8" NPS (250x200 DN)	8 (203.2)	3 (76.2)	150-600	C _v	975
12x6" NPS (300x150 DN)	7 (177.8)	2 (50.8)	150-600	C _v	729
12x8" NPS (300x200 DN)	8 (203.2)	3 (76.2)	150-600	C _v	1160
			900	C _v	1160

NOTE: For the complete list of sizing coefficients, contact Dyna-FLo.

Table 21

Quick Opening Characteristic - Maximum Sizing Coefficients

Valve Size	Port Inches (mm)	Travel Inches (mm)	ASME Class	Coefficient	Percentage of Valve Travel
					100%
8x6" NPS (200x150 DN)	7 (177.8)	2 (50.8)	150-600	C _v	637
			900	C _v	670
10x8" NPS (250x200 DN)	8 (203.2)	3 (76.2)	150-600	C _v	1040
12x6" NPS (300x150 DN)	7 (177.8)	2 (50.8)	150-600	C _v	817
12x8" NPS (300x200 DN)	8 (203.2)	3 (76.2)	150-600	C _v	1260
			900	C _v	1260

NOTE: For the complete list of sizing coefficients, contact Dyna-FLo.

Table 22

Low-Noise III A1 - Maximum Sizing Coefficients

Valve Size	Port Inches (mm)	Travel Inches (mm)	ASME Class	Coefficient	Percentage of Valve Travel
					100%
8x6" NPS (200x150 DN)	7 (177.8)	3 (76.2)	150-600	C _v	416.1
10x8" NPS (250x200 DN)	8 (203.2)	6 (152.4)	150-600	C _v	882.3
12x6" NPS (300x150 DN)	5-3/8 (136.5)	6-1/2 (165.1)	150-600	C _v	698
12x8" NPS (300x200 DN)	8 (203.2)	6 (152.4)	150-600	C _v	882.3

NOTE: For the complete list of sizing coefficients, contact Dyna-FLo.

Table 23

Anti-Cavitation 1 Stage Characteristic - Maximum Sizing Coefficients (Model 350 Only)

Valve Size	Port Inches (mm)	Travel Inches (mm)	ASME Class	Coefficient	Percentage of Valve Travel
					100%
8x6" NPS (200x150 DN)	7 (177.8)	2-1/4 (57.2)	150-600	C _v	293
		2 (50.8)	900	C _v	236
		5 (127)	900	C _v	495
12x6" NPS (300x150 DN)	7 (177.8)	2-1/4 (57.2)	150-600	C _v	305
12x8" NPS (300x200 DN)	8 (203.2)	3-3/8 (85.7)	150-600	C _v	487
		3-3/8 (85.7)	900	C _v	487
		6 (152.4)	900	C _v	690

NOTE: For the complete list of sizing coefficients, contact Dyna-FLo. Not available for Model 351 valves.

Table 24

Anti-Cavitation 2 Stage Characteristic - Maximum Sizing Coefficients (Model 350 Only)

Valve Size	Port Inches (mm)	Travel Inches (mm)	ASME Class	Coefficient	Percentage of Valve Travel
					100%
8x6" NPS (200x150 DN)	5-3/8 (136.5)	5 (127)	150-600	C _v	178
		5 (127)	900	C _v	175
12x6" NPS (300x150 DN)	5-3/8 (136.5)	6 (152.4)	150-600	C _v	208
12x8" NPS (300x200 DN)	7 (177.8)	6 (152.4)	150-600	C _v	272
		6 (152.4)	900	C _v	272

NOTE: For the complete list of sizing coefficients, contact Dyna-FLo. Not available for Model 351 valves.

350 VALVE NUMBERING SYSTEM

SAMPLE PART NUMBER: 350-64AFL-5P2-VES4

						VALVE SIZE		64
86	8X6 INCH	126	12X6 INCH	108	10X8 INCH	128	12X8 INCH	
ASME RATING								A
A	150	B	300	C	600	D	900	
END CONNECTION								F
F	RF	J	RTJ	N	NPT	T	BWE SCH 40	
L	BWE SCH 80							
BODY MATERIAL								L
L	LCC	W	WCC	M	CF8M	9	WC9	
BOLTING								-
-	B7 / 2H (STANDARD)			A	B7M / 2HM			
B	B8M / 8M			K	B7 FLUOROKOTE #1 / 2H FLUOROKOTE #1			
L	B7M FLUOROKOTE #1 / 2HM FLUOROKOTE #1							
TRIM								5
1	TRIM D1	2	TRIM D2	4	TRIM D4	5	TRIM D5	
6	TRIM D6	7	TRIM D7	8	TRIM D8	9	TRIM D9	
L	TRIM DL	J	TRIM DJ	T	TRIM DT	E	TRIM DE	
N	TRIM DN	R	TRIM DR					
PACKING STYLE								P
P	SINGLE PTFE V-RING (PRESSURE)			J	DOUBLE PTFE V-RING (PRESSURE)			
G	SINGLE GRAPHITE (PRESSURE)			V	DOUBLE PTFE V-RING (VACUUM)			
R	DOUBLE PTFE V-RING (VACUUM / PRESSURE)			L	LIVE LOADED PTFE V-RING (PRESSURE)			
T	LIVE LOADED GRAPHITE (PRESSURE)			D	LIVE LOADED DUPLEX (PRESSURE)			
K	LIVE LOADED KALREZ® (PRESSURE)			F	LIVE LOADED KALREZ® FIRE SAFE (PRESSURE)			
YOKE BOSS SIZE								2
2	2-13/16" (1/2" STEM)			3	3-9/16" (3/4" STEM)			
5	5" (1" STEM)							
PAINT								-
-	DFPS-01 (STANDARD)			2	DFPS-02 (SEVERE SERVICE)			
3	DFPS-03 (HIGH TEMPERATURE)							
BACKUP RING / SEAL RING								V
V	VITON / CARBON-FILLED PTFE			E	EPDM / CARBON-FILLED PTFE			
P	PTFE-ELGILOY (8" 350)			C	S31600 / PTFE-ELGILOY			
R	S31600 / PTFE-ELGILOY WITH PEEK AE RINGS			K	S31600 / KEL-F - ELGILOY			
CHARACTERISTIC								E
E	EQUAL PERCENT	L	LINEAR	Q	QUICK OPENING			
A	ANTI-CAVITATION 1 STAGE (LINEAR)			K	ANTI-CAVITATION 2 STAGE (LINEAR)			
Z	LOW-NOISE III A1 (LINEAR)							
CHARACTERISTIC (EXTENDED TRAVEL)								E
R	EQUAL PERCENT - EXTENDED TRAVEL			S	LINEAR - EXTENDED TRAVEL			
T	QUICK OPENING - EXTENDED TRAVEL			V	ANTI-CAVITATION 1 STAGE (LINEAR) - EXTENDED TRAVEL			
W	LOW-NOISE III A1 (LINEAR) - EXTENDED TRAVEL							
4	LOW-NOISE III A1 (LINEAR) EXTENDED 4" TRAVEL (8" VALVE ONLY)							
BONNET STYLE								S
S	STANDARD	T	STANDARD TAPPED	E	EXTENSION STYLE 1			
H	EXTENSION STYLE 2							
SHUT-OFF CLASS								4
2	CLASS II	3	CLASS III	4	CLASS IV	5	CLASS V	
6	CLASS VI							

350

Refer to Page 21 for Valve Numbering System

Curtiss-Wright Flow Control Company Canada, doing business as Dyna-Flo Control Valve Services

Headquarters: 1911 66 Avenue, Edmonton, AB, T6P 1M5 Canada • Telephone: 1-866-396-2356 • www.cw-dynaflo.com

Offices Worldwide: For a listing of our global sales network, visit our website at www.cw-dynaflo.com/en-gb/distribution

While this information is presented in good faith and believed to be accurate, Curtiss-Wright Flow Control Company Canada, doing business as Dyna-Flo Control Valve Services, does not guarantee satisfactory results from reliance on such information. Nothing contained herein is to be construed as a warranty or guarantee, expressed or implied, regarding the performance, merchantability, fitness or any other matter with respect to the products, nor as a recommendation to use any product or process in conflict with any patent. Curtiss-Wright Flow Control Company Canada, doing business as Dyna-Flo Control Valve Services, reserves the right, without notice, to alter or improve the designs or specifications of the products described herein.

© 2025 Curtiss-Wright. All rights reserved. Specifications are subject to change without notice. All trademarks are property of their respective owners.
Catalog # Model 350 Control Valve Technical Sales Bulletin