

**Figure 1** Model DF400 Control Valve and Actuator

## Principles of Operation

The Model DF400 (Figure 1) is a heavy-duty eccentric plug control valve (sometimes referred to as a rotary globe valve) combined with a powerful integral actuator. These actuators are spring-opposed rolling diaphragm style and, through a lever linkage, rotate the eccentric plug through an angle of 50 degrees. This self-aligning eccentric plug design allows for a straight through flow pattern while providing tight shutoff and allowing for higher flow capacities than other valves. The low-profile integral actuator also provides reduced deadband/hysteresis through a combination of the low-friction design and a robust splined shaft connection.

## Table of Contents

Description	Page
General Information	2
Scope of Manual	2
Safety Warnings	2
Specifications	3
Available Configurations - Table 1	4
Approximate Assembly Weights - Table 2	4
Actuator/Valve Mounting Positions - Figure 2	5
Unpacking Assembly	6
Installation	6
Air Piping	7
Periodic Inspection	8
Maintenance	8
Valve/Actuator Separation	10
Changing Operation/Orientation	13
DF400 Disassembly	14
Handwheel Removal	14
Travel Stop Removal	14
Shaft Cover Removal	15
Thread Plug Removal	15
Shaft Grommet Removal	15
Spring Barrel Disassembly	15
Seat Ring Removal	17
Shaft Removal	18
Inner Valve Parts Removal	19
Lapping	20
DF400 Assembly	21
Stud Replacement	21
Valve Body Assembly	22
Seat Ring Alignment	24
Spring Barrel Assembly	25
Yoke-to-Valve Mounting	25
Spring Barrel Sub-Assembly Installation	27
Seat Ring Retainer Wrench - Table 5	17
Seat Ring Retainer Torque - Table 6	25
Actuator Stem Adjustment	28
Actuator Bench Set Loading Pressures - Table 7	29
Travel Stop & Handwheel Installation	31
Valve & Actuator Cross Sections - Figures 63 & 64	32 & 33
Flange Stud Dimensions - Table 8 & 9	34 & 35
Parts List	36
Valve Model Numbering System	44

## Notice

These instructions are meant to be used with the Dyna-Flo DF400 Technical Bulletin as they refer to Figures and Tables therein. If you do not have the Technical Bulletin, contact Dyna-Flo immediately, or visit: [valves.curtisswright.com](http://valves.curtisswright.com)

It is the responsibility of the purchaser and end user to source and reference the latest edition of any technical or instructional literature related to the safe operation of this equipment.

Each control valve is factory checked. Check the calibration for the specific application, before a valve is put into service.

It is the intention of this document to provide users with an accurate guide for safe installation and maintenance of the DF400 Control Valves. Revisions are available at above mentioned website.

### **WARNING - GENERAL INFORMATION**

The following instructions are to be thoroughly reviewed and understood prior to installing, operating or performing maintenance on this equipment. Work on this equipment should be done by experienced personnel and it is the responsibility of the end user to perform regular maintenance and inspections on this equipment. Throughout the manual, safety warnings and caution notes appear and must be strictly followed to prevent serious injury or equipment malfunction.

### **WARNING - SCOPE OF MANUAL**

The control valve configuration and construction materials were selected to meet particular pressure, temperature, and process conditions. Some material combinations are limited in their pressure and temperature ranges. It is the responsibility of the purchaser and end user to ensure that this equipment meets the required construction material combinations for safe usage in the intended process control application. Do not apply any conditions outside the intended factory manufactured specifications to the valve without first contacting your Dyna-Flo sales office.

This manual is written to be a practical and useful guide to maintaining the Dyna-Flo DF400 Control Valve.

### **WARNING - SAFETY INFORMATION**

Only well trained experienced technicians should perform these procedures. Use safe work practices and lock out procedures when isolating valves and actuators. It is also important to wear the proper protective equipment when performing any installation or maintenance activity. It is the responsibility of the end user of this product to select the proper parts and materials rated for the process being used, temperature requirements/limitations, operating conditions, and environmental conditions products will be used in. Special paint systems are available to alleviate effects of corrosion.

To avoid personal injury or installation damage as a result of the sudden release of process pressure or damage to equipment, do not install the valve assembly where service conditions could exceed the limits stated in this manual, sales bulletin or on the equipment nameplates. Use government codes, accepted industry standards, good piping practices and select proper pressure-relieving equipment for protection of your installation. Always be aware of flammable process and instrument gas.

Always be aware of the hazards of actuators, especially spring-loaded actuators. Be sure that the actuator is de-energized or in the failed position before performing any maintenance procedure. Refer to any appropriate auxiliary equipment, instrumentation, and actuator instruction manuals; also enquire with your safety department or process engineer for additional protection measures.

These valves have dangerous pinch points. Never put your hands inside the valve unless you are certain that the plug will not move.

# Specifications

## Configurations

The Model DF400 control valve is a high capacity single port, automatic-throttling, eccentric plug rotary valve. Refer to Table 1.

PTFE Seat and Metal Seat Available.

Consult your Dyna-Flo sales office for other available configurations.

## Valve Sizes and Connection Styles (Refer to Table 1)

Model:	DF400
Size:	1" (25mm), 1-1/2" (40mm), 2" (50mm), 3" (80mm), 4" (100mm), 6" (150mm)
Body:	Cast with integral bonnet
Rating:	ASME 150 / 300 / 600
Connection:	RF - All Sizes

## Maximum Inlet Pressures and Temperatures

Flanged valves consistent with ASME Class 150, 300, and 600 rating as per ASME B16.34, unless limited.

## Valve Assembly Temperature Limitations

Refer to Table 2 of Sales Bulletin for process temperature limitations.

Refer to Tables 10 & 11 of Sales Bulletin for limiting factors specific to valve part.

## Ambient Actuator Temperature Limitation

-40°F to 180°F (-40°C to 82°C)

## Characteristic and Flow Direction

Linear - Flow-to-Open or Flow-to-Close

Refer to Figure 2 for Flow Direction.

## Cv Ratio

Standard Trim: >100:1

Reduced Port Trim: 15:1

## Maximum Valve Sizing Coefficients

For maximum coefficients at maximum opening, refer to Table 4 of Sales Bulletin.

For all standard coefficients, refer to Tables 13 & 14 of Sales Bulletin.

## Allowable Pressure Drops

Refer to Tables 15 and 16 of Sales Bulletin.

## Dimensions

Valve and Actuator Outline Dimension Diagram: Refer to Figure 2 of Sales Bulletin.

Valve and Actuator Assembly Dimensions: Refer to Tables 7 & 8 of Sales Bulletin.

## Materials

Body material options include:

WCC

CF3M

Refer to Page 35 for valve parts construction materials.

Refer to Tables 11 & 12 of Sales Bulletin for trim selections.

## Approximate Assembly Weights

Refer to Table 2.

## Cross-Section of the Model DF400 Assembly

Refer to Figures 63 to 64.

## Packing Type

The Standard packing is carbon core braided PTFE.

## Valve Plug Travel Times and Actuator Size

Refer to Table 3 of Sales Bulletin.

## Available Actuator Sizes

Refer to Table 1.

## Actuator Tubing Connection Size

All sizes - 1/4 inch (6.35 mm) NPT.

## Actuator Mounting Orientation

Refer to Figure 2.

**For more information and other options contact your Dyna-Flo sales office.**

**Table 1**

**Available Valve and Actuator Configurations**

Valve Model	Valve Size	End Connection				Actuator Size	Stroke	Operating Range
		Wafer	Raised Face (RF) Flanged					
		ASME Class 150-600	ASME Class 150	ASME Class 300	ASME Class 600			
DF400	1 inch NPS (25mm DN)	✓	✓	✓	✓	4-1/2 inch Diameter	3-1/2 inch (89 mm)	7 - 15 Psi (0.48 - 1.03 Bar)
	1-1/2 inch NPS (40mm DN)	✓	✓	✓	✓	4-1/2 inch Diameter	3-1/2 inch (89 mm)	
	2 inch NPS (50mm DN)	✓	✓	✓	✓	4-1/2 inch Diameter	3-1/2 inch (89 mm)	
	3 inch NPS (80mm DN)	✓	✓	✓	✓	6 inch Diameter	5-3/4 inch (146 mm)	
	4 inch NPS (100mm DN)	✓	✓	✓	✓	6 inch Diameter	5-3/4 inch (146 mm)	
	6 inch NPS (150mm DN)	✓	✓	✓	✓	7 inch Diameter	7-1/4 inch (178 mm)	7 - 24 Psi (0.48 - 1.65 Bar)

**Table 2**

**Approximate Valve/Actuator Assembly Weights**

Valve Size	Actuator Size	Wafer Class 150-600		ASME Class 150		ASME Class 300		ASME Class 600	
		lbs.	Kg	lbs.	Kg	lbs.	Kg	lbs.	Kg
1 Inch (25mm)	4-1/2 Inch	38	17	40	18	44	20	44	20
1-1/2 Inch (40mm)	4-1/2 Inch	42	19	48	22	53	24	55	25
2 Inch (50mm)	4-1/2 Inch	44	20	53	24	60	27	62	28
3 Inch (80mm)	6 Inch	101	46	115	52	126	57	130	59
4 Inch (100mm)	6 Inch	119	54	143	65	161	73	183	83
6 Inch (150mm)	7 Inch	227	103	254	115	289	131	344	156

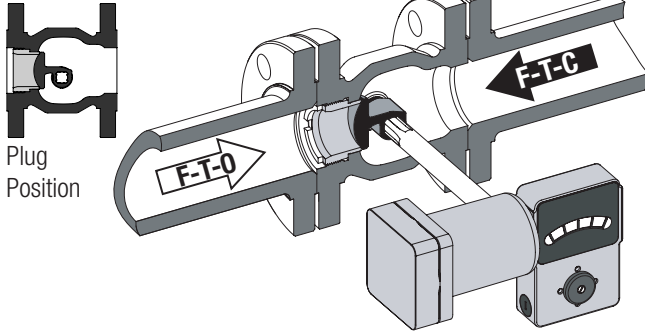
**Table 3**

**Figure 2 - Actuator Mounting Positions Notes**

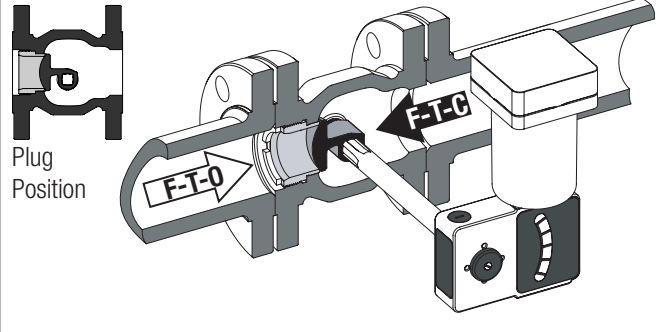
- Grey shaded actuators represent standard actuator mounting positions.
- Black arrows represent the recommended flow direction. F-T-C = Flow-to-Close F-T-O = Flow-to-Open
- Installation of valve and actuator is assumed and recommended to be in the horizontal position (parallel to the ground). Consult Dyna-Flo regarding installation of the assembly into positions other than horizontal.
- Valve plug positions are shown in their starting positions (position without air applied to the actuator).
- Operating efficiencies may vary depending on valve/actuator orientation and configuration.

**Fail Close (Air-to-Open) Configurations**

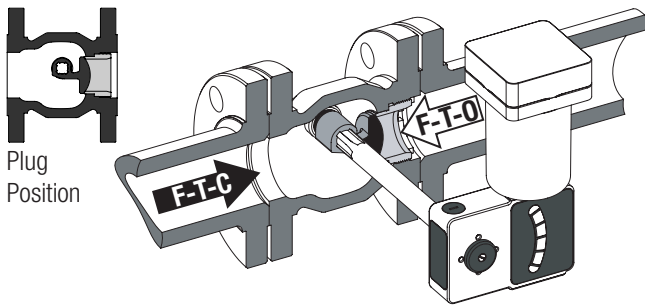
**Actuator Position 2**



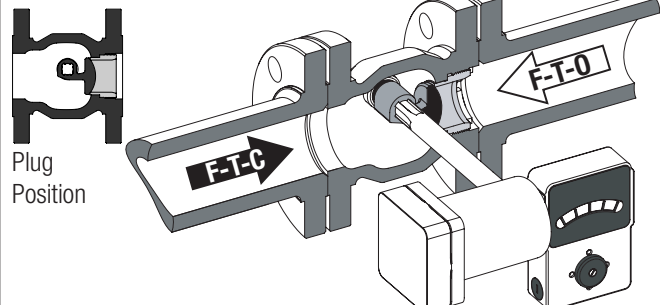
**Actuator Position 4**



**Actuator Position 8**

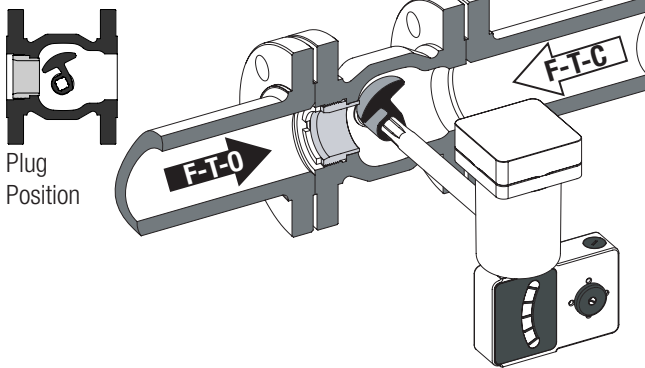


**Actuator Position 6**

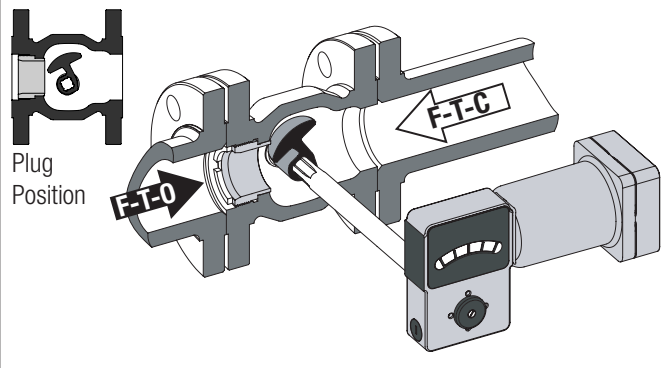


**Fail Open (Air-to-Close) Configurations**

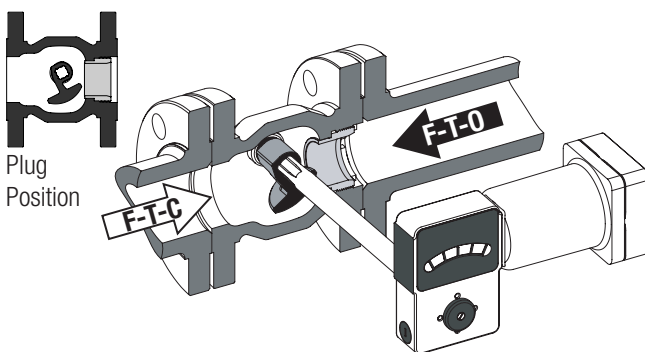
**Actuator Position 3**



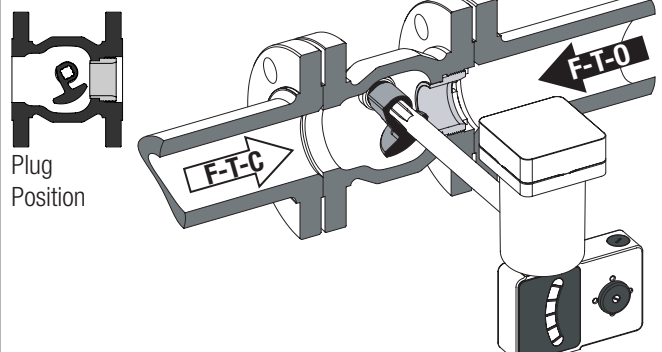
**Actuator Position 1**



**Actuator Position 5**



**Actuator Position 7**



**Figure 2** Actuator Mounting Positions in Relation to Valve Body (Refer to Table 3 on Page 4 for Notes)

## Unpacking Valve From Shipping Container

### Special Tools Required:

- Properly Rated Lifting Straps (2 – 4 Straps) refer to Table 3 for valve/actuator weights.
- Lifting Device (Example: Crane)

Check the packing list, verify that the list includes all the proper items in the shipping container before unpacking. Valve information can be found on the nameplate (Key 232), verify that the product is correct. Refer to Figure 3 for nameplate location.

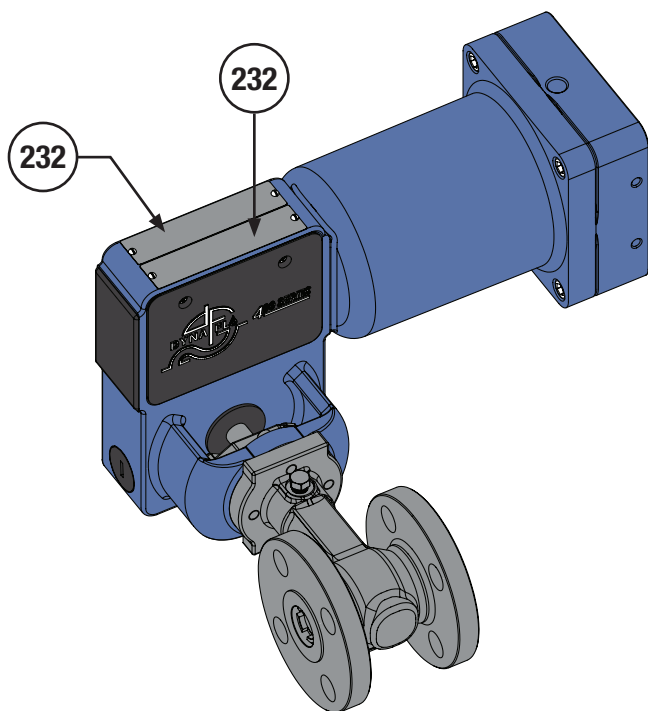
**! WARNING**

Avoid sharp edges and corners when removing equipment from shipping container.

When lifting the valve assembly from shipping container, place properly rated lifting straps securely around the neck of the actuator and valve body. Straps should be placed to avoid damage to tubing and other mounted accessories.

Lift the valve/actuator assembly using proper lifting techniques.

**NOTE:** DF400 assemblies with handwheels are shipped without the handwheel installed on the assembly, this prevents damage. For handwheel assembly instructions, refer to Travel Stop and Handwheel Installation (Page 31).



**Figure 3** DF400 Nameplate Location

## Installation

**! WARNING**

**Before You Begin:**

- Read the Warnings on Page 2.
- Sudden movement of actuator can cause damage or injury. Remove any operating medium to the actuator before performing any work. Although the handwheel is designed to be used for emergency operation, if the valve assembly is equipped with a handwheel (Key 300) or travel stop (Key 400), it may be possible to adjust these devices and immobilize actuator movement altogether. To adjust the travel stop and handwheel, loosen Keys 302 and 401, refer to Figure 5.
- Use safe work practices and lock out procedures before placing valve or actuator in-line.
- Always wear the appropriate personal protective equipment.
- Do not use operating pressure that exceeds the Maximum Actuator Casing Pressure. Refer to Table 4.
- Property damage, environmental harm, and personal injury can result from the use of supply gas other than clean, non-corrosive, oil and moisture free air.
- Operating medium must be controlled and directed, if a positioner was not ordered or unavailable, use a loading device such as a 4-way switching valve or regulator. For more information on positioner installation and operation, refer to the appropriate positioner instruction manual for your positioner type.
- Valve packing leakage could cause property damage or personal injury. Valve packing was properly tightened in factory, however, it is recommended that packing tightness be checked prior to installation.
- It is important that the DF400 valve assembly be installed in the pipeline so that process flows through the valve in the direction indicated by the flow arrow. Refer to the nameplate (Key 232) and Figure 2 for valve orientation representations. Refer to Changing Operation/Orientation on Page 13 if required.

### Parts Required:

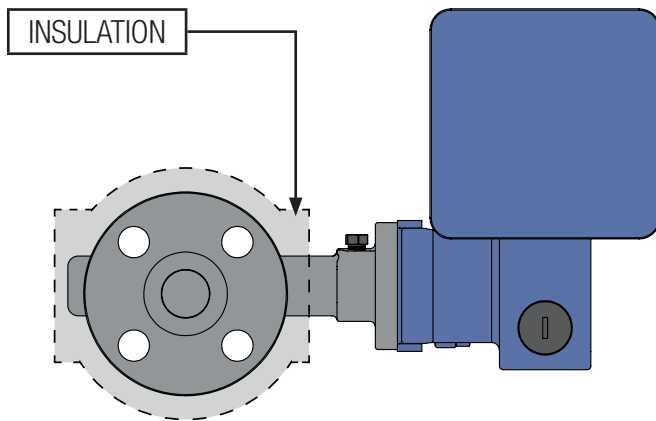
- Appropriate Line Flange Nuts and Bolts.
- Appropriate Line Flange Gaskets.

**! CAUTION**

Do not insulate the neck of the valve if the valve body is to be insulated. Refer to Figure 4 for suggested placement of insulation.

### Installation Steps:

- 1 Clean any dirt, oil/grease and foreign material from the valve cavity, valve shaft (Key 112), line piping, and gasket sealing surfaces.

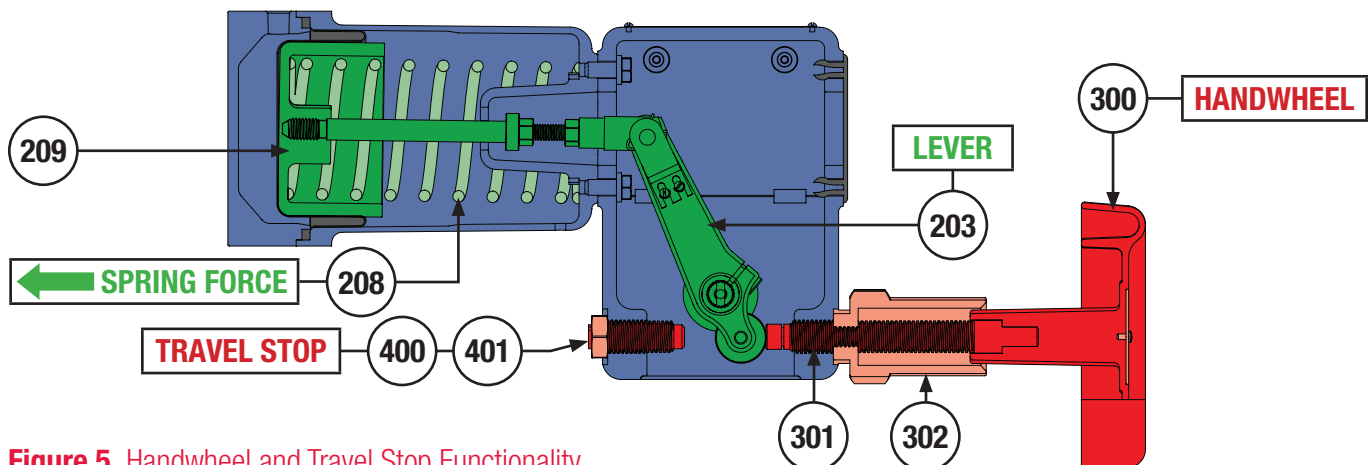


**Figure 4** Insulation Placement Around Valve Body

## Installation (Continued)

### Installation Steps (Continued):

- 2 Check the packing box bolting (Keys 102 & 122) for proper tightness. Refer to Yoke-to-Valve Mounting on Page 26 for proper packing tightening instructions.
- 3 The valve assembly may be installed in any position unless limited by vibration considerations, it is however recommended that the valve be installed with the valve shaft (Key 112) in the horizontal position (parallel to the ground). **NOTE:** For some non-vertical orientations, the valve actuator may need to be supported.
- 4 Install the valve with flow through the valve in the direction shown by the flow arrow on the valve body. Apply Permatex® Nickel Anti-Seize to the threads of the flange studs and install. **NOTE:** For some valve sizes, it may not be possible for flange studs to span both sets of flanges as the neck of the valve body (Key 100) may interfere. Refer to Tables 8 & 9 on Pages 34 & 35 for flange stud recommendations.



**Figure 5** Handwheel and Travel Stop Functionality

- 5 Install the appropriate line flange gaskets.

### **! WARNING**

Spiral wound gaskets form their seal by being crushed and cannot be reused. Always use new gaskets.

- 6 When possible, before tightening the line bolting, stroke the valve and check for smooth operation through the full stroke. Unsteady valve stem movement could be an indication of an internal problem. **NOTE:** When maximum allowable supply pressure is applied to the actuator (refer to Air Piping), the valve should fully open or fully close (depending on configuration). Valve position will be displayed by the travel indicator (Key 221). Refer to Figure 54 for the acceptable and unacceptable positions of the travel indicator. Refer to Actuator Stem Adjustment (Page 28) for adjustment options. Unacceptable travel indicator positioning could also be an indication of an internal problem.
- 7 Tighten the line flange bolting in even increments in a crisscross pattern until the correct line bolt torque specification is reached.

### Air Piping:

#### Before You Begin:

**NOTE:** Standard actuators accept ¼" (6 mm) NPT connections. Refer to Table 4 for the proper actuator supply pressure required.

#### Piping Installation Steps:

- 1 Use 3/8" (8x10mm) outside diameter tubing (or equivalent) for air lines. **NOTE:** If a Positioner or Regulator is attached to the assembly from factory, connect the supply lines to the instrumentation as appropriate.
- 2 Install the required line vents, accessory valves, drains, seals, and filters to the actuator or instrumentation.
- 3 Adjust the travel stop and handwheel as needed.

**Table 4**

**Maximum Allowable Actuator Supply Pressure**

Valve Size	Actuator Size	Maximum Supply Pressure	
		PSI	BAR
1" NPS (25mm DN)	4-1/2" (114mm)	20	1.38
2" NPS (50mm DN)	4-1/2" (114mm)	30	2.07
3" NPS (80mm DN)	6" (152mm)	30	2.07
4" NPS (100mm DN)	6" (152mm)	45	3.10
6" NPS (150mm DN)	7" (177mm)	60	4.48

**Periodic Inspection**

**! WARNING**

**Before You Begin:**

- Read the Warnings on Page 2.
- Use safe work practices and lock out procedures before taking valve out of line.
- Relieve process pressure and drain the process fluid from up and down stream of valve.
- Be aware of potentially hazardous process material that may be present in-line and in-valve (especially valve packing). Isolate the valve from process pressure. Use a bypass or block valve if necessary, or completely shut off the process. Refer to the appropriate equipment manuals and enquire with your safety department or process engineer for additional protection measures.
- Seals, soft parts, and packing should all be inspected frequently for leaks, wear and damage. It is the responsibility of the end user to perform regular inspections and maintenance on this equipment.

**Inspection Steps:**

- 1 Check for visible signs of leakage around all seal and gasket areas.
- 2 Check the assembly for damage, especially damage caused by corrosive fumes or process drippings.
- 3 Clean and repaint areas as required.
- 4 Ensure all accessories, mounting brackets, and fasteners are secure.
- 5 Clean any dirt and foreign material from the valve shaft (Key 112).
- 6 Verify that the valve packing is properly tightened. Refer to ASSEMBLY, Yoke-to-Valve Mounting (Page 26, Step 4) for tightening instructions.

**Maintenance**

**NOTE:** Recommended maintenance for the DF400 without disassembly is limited to checking for proper packing tightness, lubricating the handwheel screw (Key 301), and diaphragm (Key 211) replacement for the actuator. The seat ring (Key 113) may also be changed, but this will require the valve to be removed from pipeline (refer to DISASSEMBLY, Seat Ring Removal, Page 16).

**! WARNING**

**Before You Begin:**

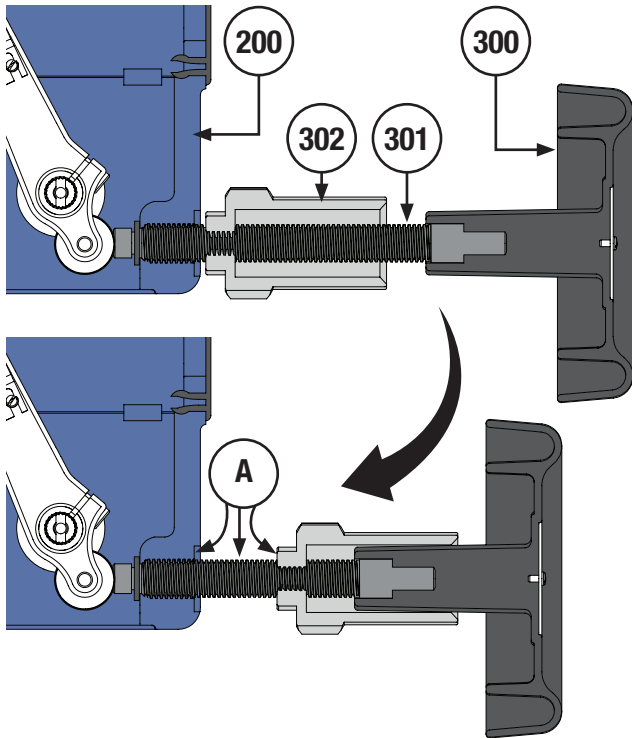
- Read the Warnings on Page 2, the Periodic Inspection WARNING and Installation WARNING.
- Use safe work practices and lock out procedures before working on equipment.
- Be aware of potentially hazardous process material that may be present in-line and in-valve (especially valve packing).
- It is the responsibility of the end user to perform regular maintenance and inspections on this equipment.
- Sudden movement of actuator can cause damage or injury. Turn off and vent any operating medium supplied to the actuator before performing any work. If maintenance is to be performed on the diaphragm (Key 211), disconnect any tubing or instrumentation attached to the diaphragm casing (Key 212). Diaphragm can be removed without separating the actuator from the valve.

**Lubricants Required:**

- Permatex® Nickel Anti-Seize or equivalent (Key A)
- 3M™ Rubber & Vinyl 80 Spray Adhesive or equivalent (Key E)

**Handwheel Maintenance:**

- 1 Verify that the actuator is safe to work on and then loosen the handwheel lock (Key 302). Turn the handwheel (Key 300) counter clockwise until all the available handwheel stem (Key 301) has been backed out of the yoke (Key 200).



**Figure 6** Handwheel Lubrication Diagram

## Maintenance (Continued)

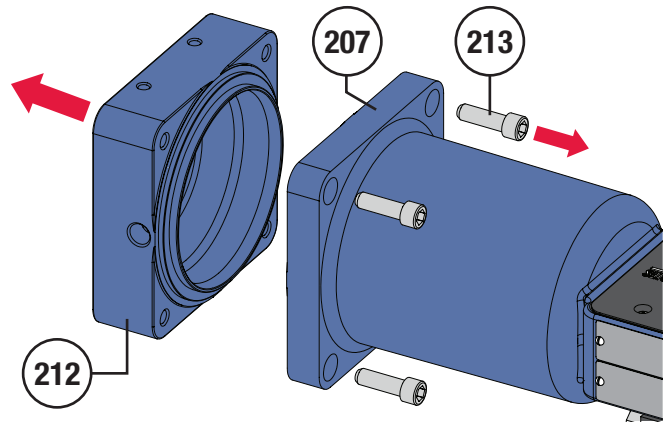
### Handwheel Maintenance (Continued):

- Turn the handwheel lock (Key 302) counter clockwise until the handwheel stem (Key 301) is accessible/exposed. Lubricate the threads of the handwheel stem and the faces of the yoke/handwheel lock that touch with Permatex® Nickel Anti-Seize (Key A). Refer to Figure 6. **NOTE:** For instructions on handwheel removal, refer to DISASSEMBLY, Handwheel Removal (Page 14).
- Re-position the handwheel (Key 300) to desired setting. Lock the handwheel in place by tightening the handwheel lock (Key 302) into the yoke (Key 200).

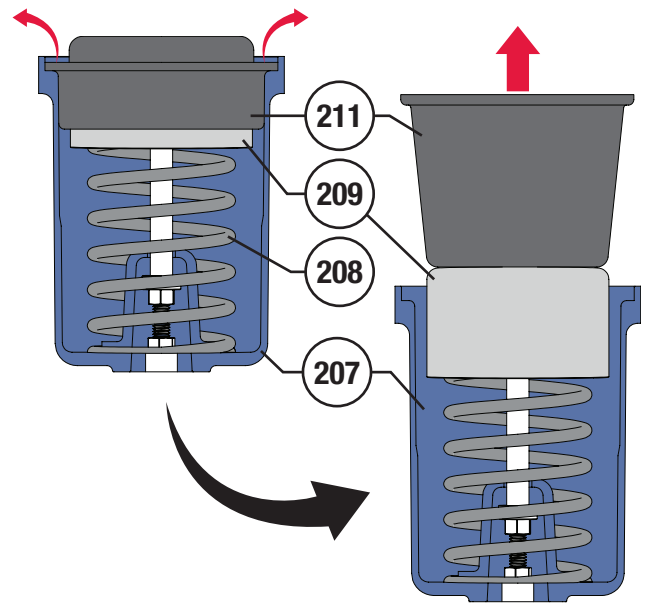
### Diaphragm Maintenance:

- If the actuator is equipped with either a handwheel (Key 300) or travel stop (Key 400), loosen them and relieve any contact they may have with the lever (Key 203).
- Remove the 4 cap screws (Key 213) from the diaphragm case (Key 212) and then remove the diaphragm case. **NOTE:** It is recommended to record the position of the diaphragm case prior to removal, this will make reassembly easier.
- Remove the diaphragm (Key 211). **NOTE:** The diaphragm is glued to the top of the piston (Key 209) but can be separated.

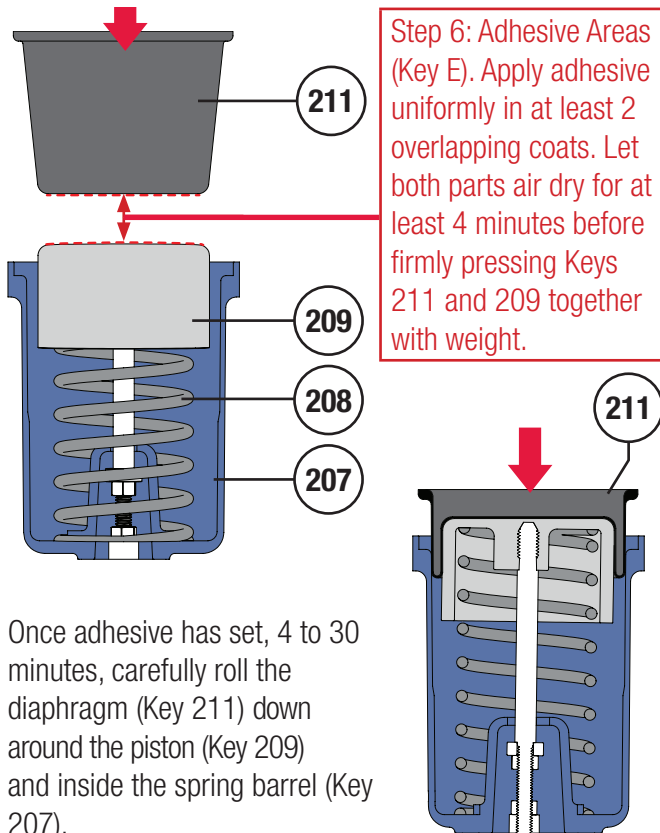
- Remove all adhesive and thoroughly clean the top surface of the piston (Key 209).
- Thoroughly clean the diaphragm groove on the diaphragm case (Key 212) and spring barrel (Key 207).
- The diaphragm (Key 211) must be connected to the top of the piston (Key 209) with an adhesive, Dyna-Flo recommends 3M™ Rubber & Vinyl 80 Spray Adhesive. Adhesive should be applied to both the surface of the piston and the rougher surface of the diaphragm cup, left to get tacky, combined, and left to cure in accordance with the manufacturer's instructions, refer to Figure 9 for recommended gluing instructions.



**Figure 7** Diaphragm Case Removal

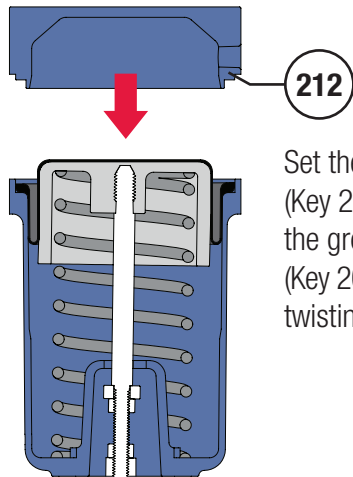


**Figure 8** Diaphragm Removal



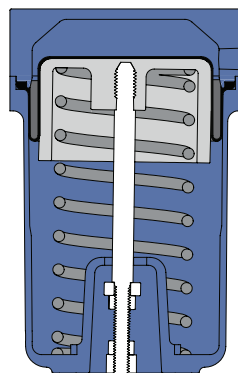
Step 6: Adhesive Areas (Key E). Apply adhesive uniformly in at least 2 overlapping coats. Let both parts air dry for at least 4 minutes before firmly pressing Keys 211 and 209 together with weight.

Once adhesive has set, 4 to 30 minutes, carefully roll the diaphragm (Key 211) down around the piston (Key 209) and inside the spring barrel (Key 207).



Set the bead of the diaphragm (Key 211) securely and evenly in the groove of the spring barrel (Key 207). Make sure there is no twisting in the diaphragm.

Clamp the bead of the diaphragm (Key 211) securely between the diaphragm case (Key 212) and the spring barrel (Key 207). The diaphragm must be seated evenly forming an air tight seal.



**Figure 9** Diaphragm Adhesive Installation Process

**Maintenance (Continued)**

**Diaphragm Maintenance (Continued):**

- 7 Re-install the 4 cap screws (Key 213) and tighten them evenly in a crisscross pattern, applying evenly distributed pressure around the diaphragm (Key 211) as tightened.
- 8 When ready and safe, apply the maximum allowable supply pressure to the actuator and verify the seal integrity. Use a soapy solution to check for any air leaks from the diaphragm (Key 211). **CAUTION:** Applying supply pressure to the actuator will cause the valve to move, avoid damage and injury as movement occurs.

**Valve/Actuator Separation**

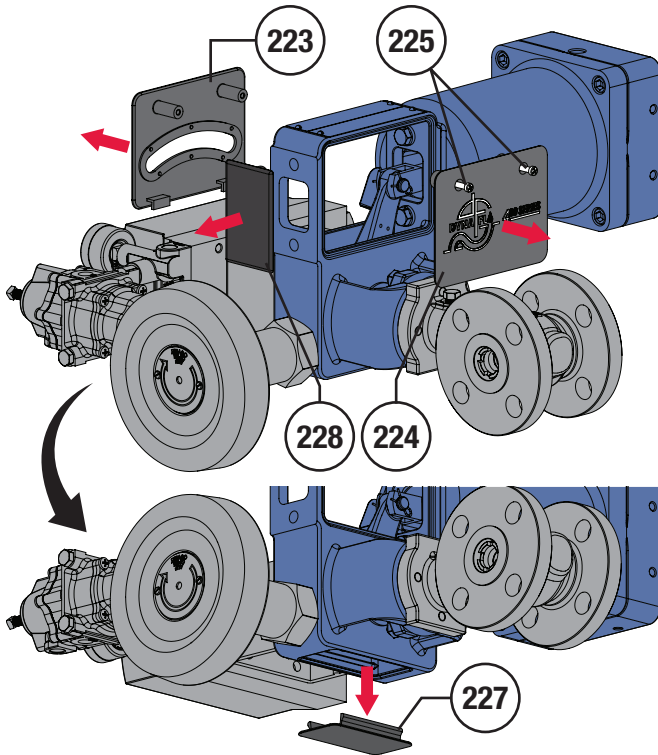
**! WARNING**

**Before You Begin:**

- Read the Warnings on Page 2. Use appropriate safe work practices and lock out procedures.
- Relieve process pressure and drain the process fluid from up and down stream of valve.
- Sudden movement of actuator can cause damage or injury. Remove any operating medium to the actuator and remove any tension applied by either a travel stop or handwheel before performing any work. To adjust the travel stop and handwheel, loosen Keys 302 and 401, refer to Figure 5.
- Always wear the appropriate personal protective equipment.
- Do not use operating pressure that exceeds the Maximum Actuator Casing Pressure. Refer to Table 4.
- Property damage, environmental harm, and personal injury can result from the use of supply gas other than clean, non-corrosive, oil and moisture free air.

**NOTE:** The actuator can be separated from the valve while the valve body remains in the pipeline. Support the weight of the actuator using properly rated lifting hooks or straps. If the valve assembly has been removed from the pipeline, place the DF400 assembly on a flat work surface or clamping device that can support the weight (Table 2).

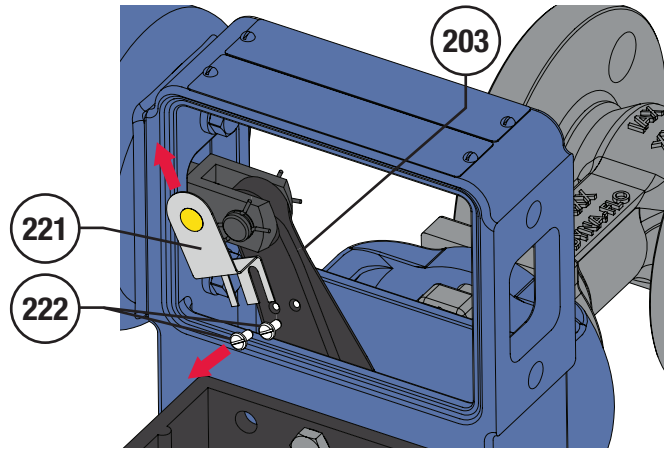
- 1 Separating the valve body (Key 100) from the actuator will require the disconnection of any instrumentation connected to the valve shaft (Key 112), spring barrel (Key 207) and diaphragm case (Key 212). Refer to the appropriate instrument instruction manuals.
- 2 Loosen the two machine screws (Key 225) until the rear cover (Key 224) and front cover (Key 223) can be removed. **NOTE:** Each machine screw is retained in the cover using a retainer o-ring (Key 226), removal of the screws will force out the o-rings.
- 3 Remove the bottom cover (Key 227) and side cover (Key 228) on the spring barrel boss of the yoke (Key 200).



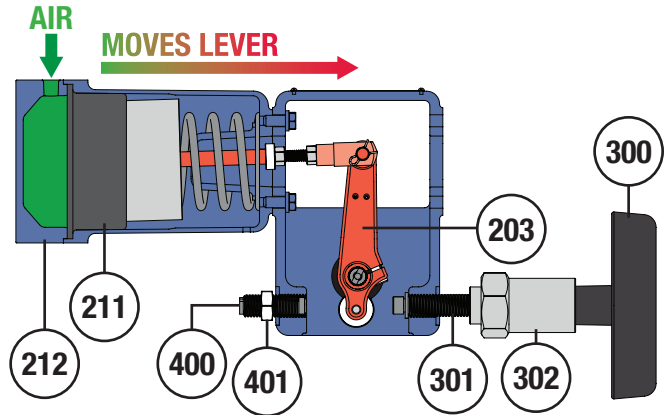
**Figure 10** Access Cover Removal (Step 2)

### Valve/Actuator Separation (Continued)

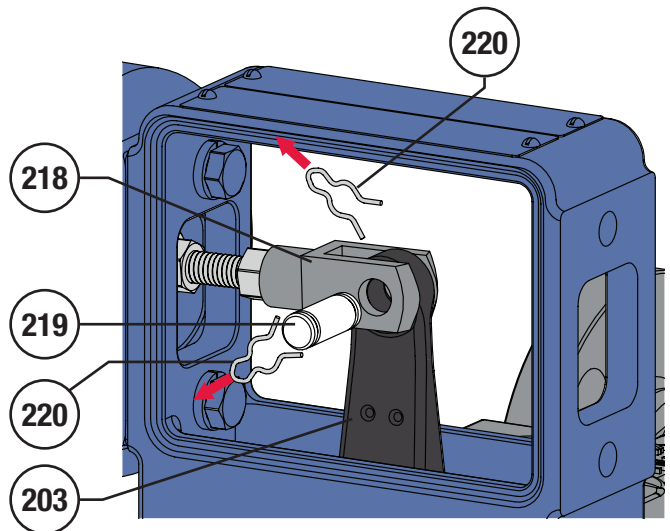
- 4 Loosen the machine screws (Key 222) and remove the travel indicator (Key 221).
- 5 If installed, remove any possible interference between a handwheel and/or travel stop with the lever (Key 203). Loosen the handwheel lock (Key 302) and turn the handwheel (Key 300) until the handwheel stem (Key 301) can no longer interfere with the lever. Loosen the locknut (Key 401) and adjust the travel stop (Key 400) (refer to Figure 5). **NOTE:** For smaller sized valve and actuator assemblies, it may be necessary to completely remove the handwheel assembly from the yoke (Key 200). Refer to DISSASSEMBLY, Handwheel (Page 14).
- 6 Connect a regulated air supply to the supply port of the diaphragm case (Key 212) and supply enough air to move the lever (Key 203) to about the middle of the yoke (Key 200).
- 7 Remove the clevis pin clips (Key 220) and clevis pin (Key 219). **NOTE:** It is recommended that the position of the lever (Key 203) to the valve shaft (Key 112) be marked or recorded for reassembly purposes.
- 8 Relieve the air pressure supplied to the actuator. **CAUTION:** Relieving supplied air to the actuator will cause the piston stem (Key 210) to move allowing the lever (Key 203) and clevis (Key 218) to separate.



**Figure 11** Travel Indicator Removal (Step 4)



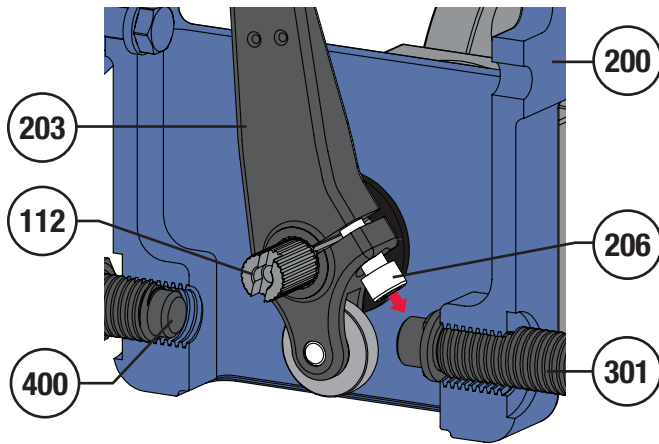
**Figure 12** Desired Lever Position (Steps 5 & 6)



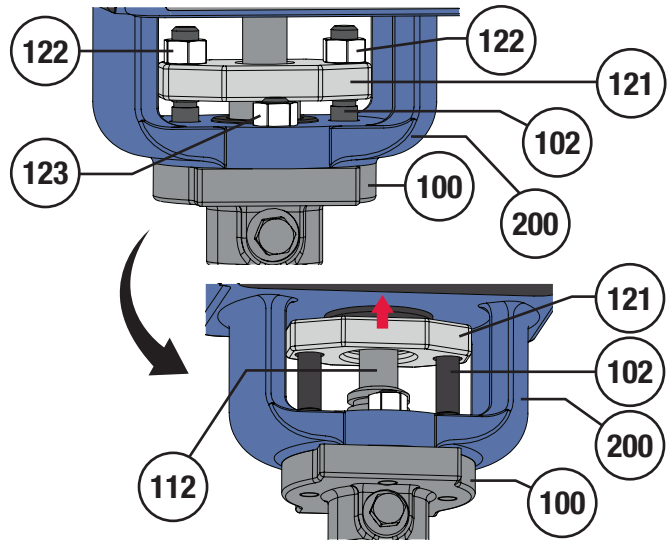
**Figure 13** Clevis Pin Removal

**Valve/Actuator Separation (Continued)**

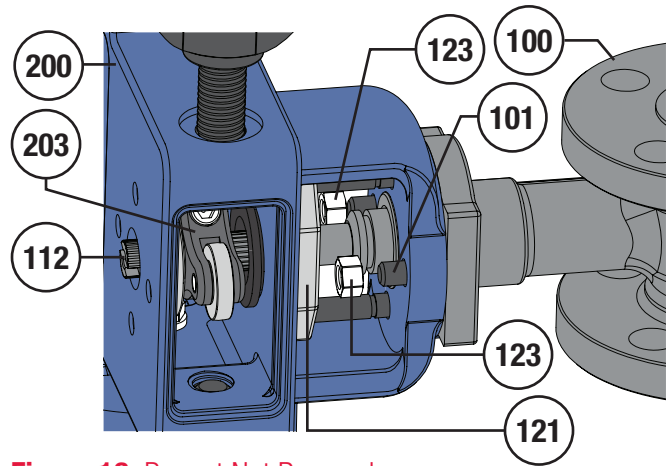
- 9 Loosen the machine screw (Key 231) and remove the shaft cover (Key 230) if installed. **NOTE:** Shaft covers are not used when the valve assembly is equipped with a positioner.
- 10 Loosen the lever cap screw (Key 206). Refer to Figure 14.
- 11 Remove the packing nuts (Key 122) and free the packing flange (Key 121) from the packing studs (Key 102).
- 12 With the valve and actuator properly supported, remove the nuts (Key 123) and separate the valve from the actuator. **NOTE:** It may be necessary to gently tap on parts with a rubber mallet to aid with separation. The lever (Key 203), packing flange (Key 121) and shaft bearing (Key 102) will also be removed when the valve shaft (Key 112) exits the yoke (Key 200), use caution and avoid letting them fall.



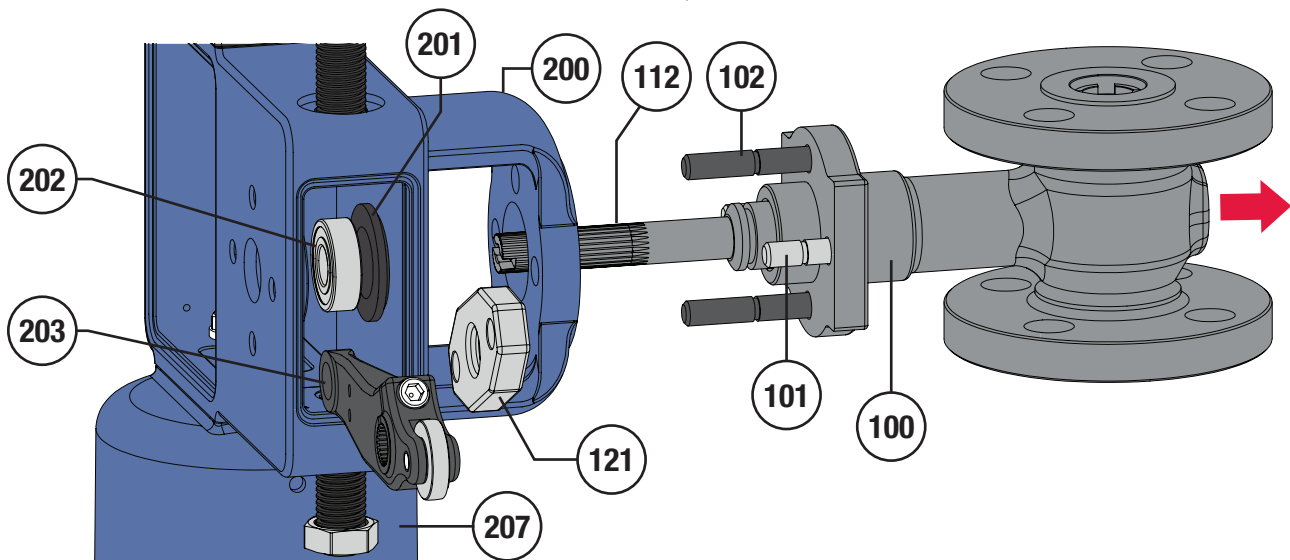
**Figure 14** Lever Cap Screw Loosening



**Figure 15** Packing Flange Placement



**Figure 16** Bonnet Nut Removal



**Figure 17** Valve Body/Actuator Yoke Separation

## Changing Operation/Orientation

**NOTE:** Refer to Figure 2 for acceptable valve and actuator positions.

### **! WARNING**

#### Before You Begin:

- Changing the position of the actuator, valve body, or direction of flow can severely impact the conditions of operation for this product. It is recommended that the valve and actuator be re-sized to ensure safe operation of product with new configuration for process conditions.
- Read the Warnings on Page 2. Use appropriate safe work practices and lock out procedures.
- Always wear the appropriate personal protective equipment.
- After changing the valve body position or actuator action, always perform an Actuator Stem Adjustment (Page 28).

## Changing Valve Body Position:

**NOTE:** The position of the valve body can be rotated around the mounting pad of the actuator yoke (Key 200) as shown in Figure 2.

- 1 Changing the valve body position requires the valve be separated from the actuator, follow Valve/Actuator Separation instructions beginning on Page 10.
- 2 After the valve body (Key 100) has been separated from the actuator yoke (Key 200), refer to the mounting instructions (ASSEMBLY, Yoke-to-Valve Mounting) on Page 25 to mount the valve to the actuator in a new position.

## Changing Actuator Action:

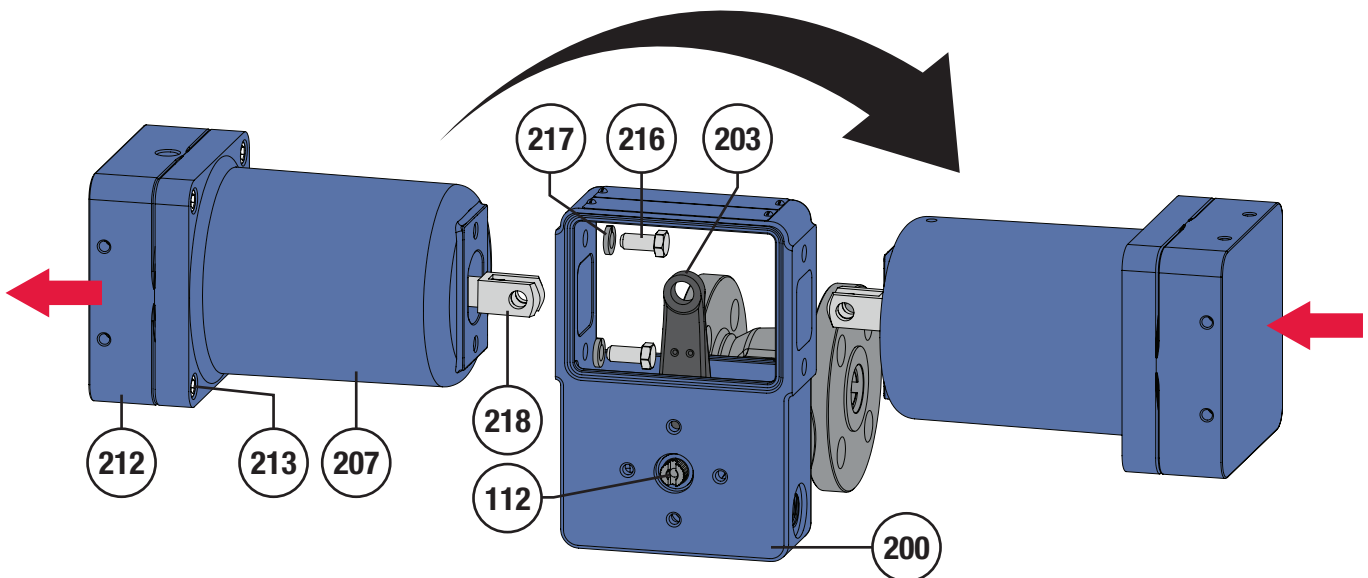
Changing the action of the actuator will change the fail position. The action will be changed from either spring-to-open or spring-to-close.

### **! WARNING**

The actuator spring (Key 208) is stored under compression inside the spring barrel (Key 207). To change the action of the actuator, it is not necessary to disassembly the spring barrel assembly. For safe instructions on the disassembly of the spring barrel assembly, refer to DISASSEMBLY, Spring Barrel, Page 15.

**NOTE:** The position of the spring barrel (Key 207) can be moved to the other side of the actuator yoke (Key 200), this will reverse the direction of spring action on the lever (Key 203). Changing the actuator action may also require the position of the valve body be changed. Refer to Figure 2.

- 1 Perform Steps 1 to 8 of the Valve/Actuator Separation instructions beginning on Page 10.
- 2 After air pressure to the actuator has been vented and the lever (Key 203) separated from the clevis (Key 218), ensure that the spring barrel assembly (Key 207) is properly supported and ready for removal.
- 3 Remove the cap screws (Key 216) and lockwashers (Key 217), then separate the spring barrel assembly from the yoke (Key 200).



**Figure 18** Spring Barrel Assembly Removal - Changing Actuator Action

## Changing Operation/Orientation (Continued)

### Changing Actuator Action (Continued):

- 4 Secure the spring barrel assembly to the opposite mounting pad using the cap screws (Key 216) and lockwashers (Key 217), tighten the cap screws completely. **NOTE:** When re-mounting the spring barrel assembly, it is important to consider the placement of vent holes and tubing paths to reconnect instrumentation.
- 5 If the handwheel and travel stop had been removed, re-install them, refer to Travel Stop and Handwheel Installation on Page 31. **NOTE:** Handwheel placement is always chosen to oppose spring (Key 208) force, install the handwheel to whichever side is opposite of where the spring pulls the lever (Key 203) to.
- 6 Re-assemble the actuator (refer to ASSEMBLY instructions on Page 25). **NOTE:** Once re-assembled, an Actuator Stem Adjustment must be performed, refer to Page 25. Also, refer to the Installation instructions on Page 6 to place the valve assembly back in service.

## Disassembly

### **! WARNING**

#### Before You Begin:

- Read the Warnings on Page 2.
- Sudden movement of actuator can cause damage or injury. Remove any operating medium to the actuator before performing any work. Although the handwheel is designed to be used for emergency operation, if the valve assembly is equipped with a handwheel (Key 300) or travel stop (Key 400), it may be possible to adjust these devices and immobilize actuator movement altogether. To adjust the travel stop and handwheel, loosen Keys 302 and 401, refer to Figure 5.
- Use safe work practices and lock out procedures before removing the valve or actuator from pipeline.
- Always wear the appropriate personal protective equipment.
- Relieve process pressure and drain the process fluid from up and down stream of valve.
- Be aware of potentially hazardous process material that may be present in-line and in-valve (especially in valve packing). Isolate the valve from process pressure. Use a bypass or block valve if necessary, or completely shut off the process. Refer to the appropriate valve instruction manual and enquire with your safety department or process engineer for additional protection measures.
- Remove the assembly from the pipeline using properly rated lifting hooks or straps. Place the DF400 assembly on a flat work surface or in a clamping device that can support the weight (Table 2).

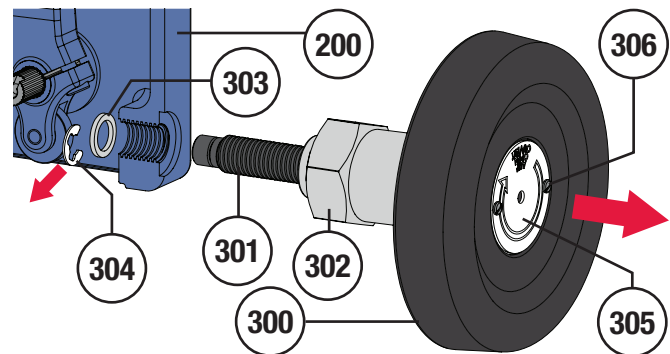
### Special Tools Required:

- Deep Socket Wrench
- Seat Ring Retainer Wrench (Refer to Page 17).

- 1 Separate the actuator from the valve by following the Valve/ Actuator Separation instructions beginning on Page 10. **NOTE:** Separation must be performed before a complete disassembly of the valve and actuator is possible.

### Handwheel Removal (Actuator):

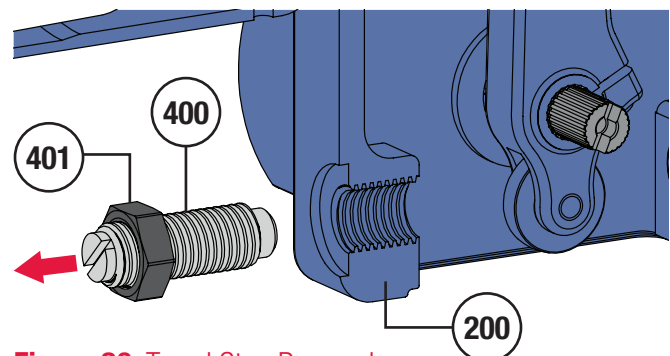
- 1 Remove the E-clip (Key 304) and washer (Key 303) from the handwheel stem (Key 301).
- 2 Unscrew and remove the rest of the handwheel assembly (Keys 300, 301, 302, 305, 306) from the yoke (Key 200).
- 3 Clean and inspect all parts for damage. Replace or repair parts as necessary.



**Figure 19** Handwheel Removal

### Travel Stop Removal (Actuator):

- 1 Loosen the locknut (Key 401) and remove the travel stop (Key 400). **NOTE:** The locknut of some travel stops are located inside the yoke (Key 200), refer to Figure 61.
- 2 Clean and inspect all parts for damage. Replace or repair parts as necessary.



**Figure 20** Travel Stop Removal

## Disassembly (Continued)

### Shaft Cover Removal (Actuator):

- 1 Remove the cap screw (Key 231) and then remove the shaft cover (Key 230). Clean and inspect all parts for damage and replace as necessary.

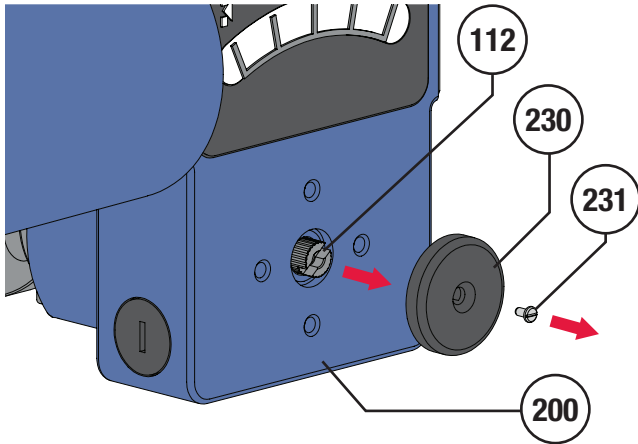


Figure 21 Shaft Cover Removal

### Thread Plug Removal (Actuator):

- 1 Use a large flat head screw driver and remove the thread plug (Key 229) from the yoke (Key 200). Clean and inspect thread plug for damage and replace as necessary.

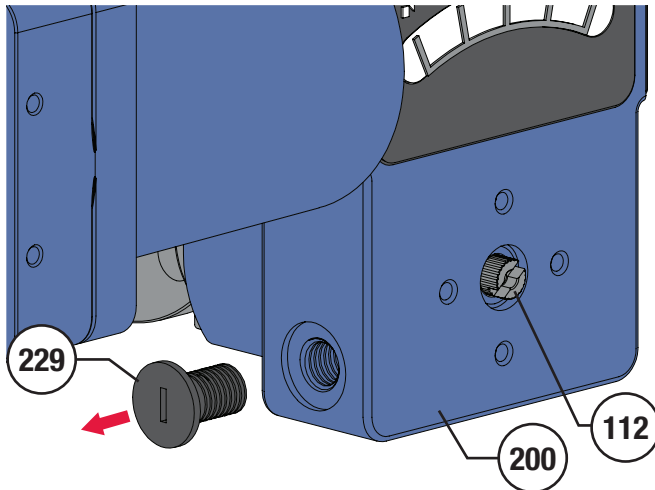


Figure 22 Thread Plug Removal

### Shaft Grommet Removal (Actuator):

- 1 Clean and inspect the shaft grommet (Key 201) for damage and wear. Remove and replace the shaft grommet from the yoke (Key 200) if necessary.

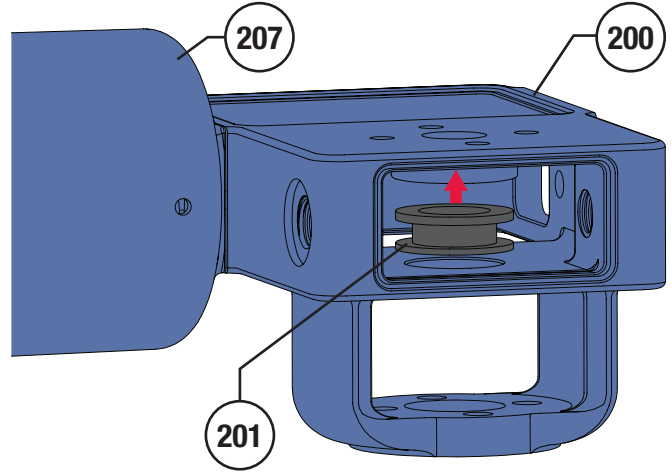
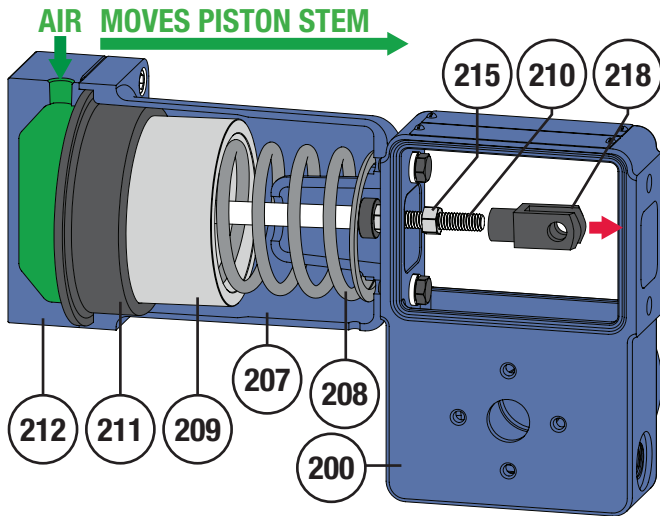


Figure 23 Shaft Grommet Removal

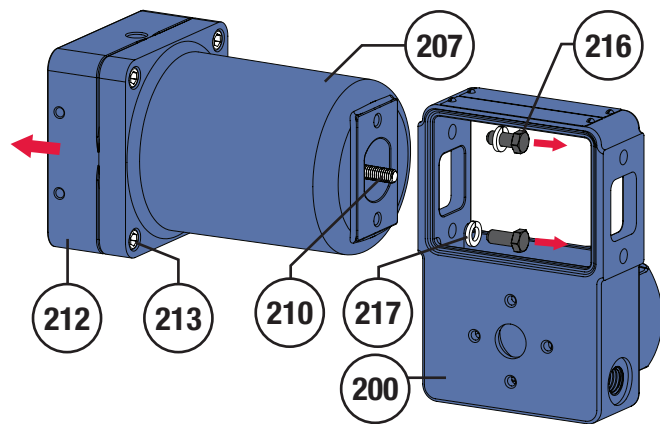
### Spring Barrel Disassembly (Actuator):

**NOTE:** Valve/actuator separation must have already been performed and the clevis (Key 218) separated from the lever (Key 203).

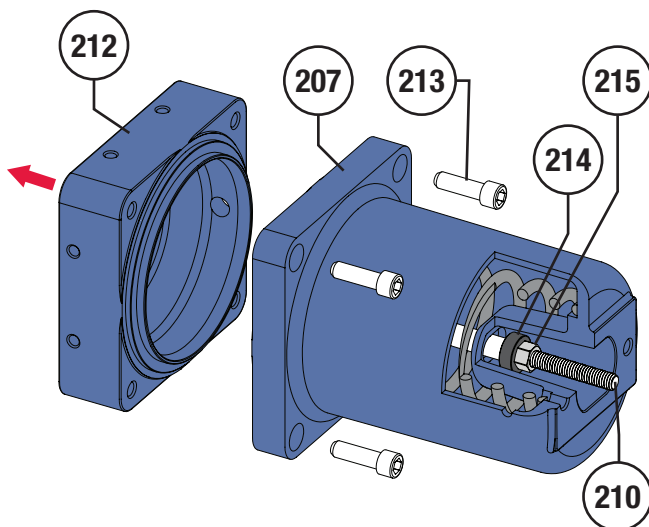
- 1 Connect a regulated air supply to the supply port of the diaphragm case (Key 212) and supply enough air to move the piston stem (Key 210) to expose the clevis (Key 218) and clevis locknut (Key 215). Mark the position of the clevis on the piston stem and remove it and the locknut from them from the stem.
- 2 Vent all air pressure to the spring barrel assembly.
- 3 Properly support the weight of the spring barrel assembly. Remove the cap screws (Key 216) and lockwashers (Key 217), then separate the spring barrel assembly from the yoke (Key 200).
- 4 Remove the cap screws (Key 213) and remove the diaphragm case (Key 212).
- 5 Pull the diaphragm (Key 211) out of the spring barrel (Key 207).  
**NOTE:** It might not be necessary to separate the diaphragm from the piston (Key 209) if the diaphragm is in good shape. For instructions on replacing the diaphragm, refer to MAINTENANCE, Diaphragm Maintenance on Page 9.
- 6 Using a deep socket wrench, slowly loosen and remove the lock nut (Key 215) and stem travel stop (Key 214). **CAUTION:** The spring (Key 208) is under tension, loosening the lock nut will remove spring tension and expand the spring.



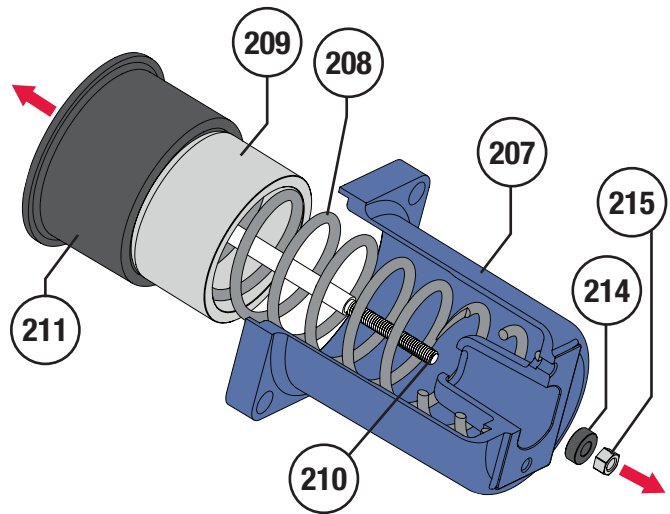
**Figure 24** Clevis Removal



**Figure 25** Spring Barrel Assembly Removal



**Figure 26** Diaphragm Case Removal



**Figure 27** Piston and Spring Removal

**Disassembly (Continued)**

**Spring Barrel Disassembly (Continued):**

- 7 Pull the piston/piston stem (Keys 210 & 211) out of the spring barrel (Key 207) and remove the spring (Key 208). **NOTE:** The piston stem is press fit to the piston at factory and cannot be separated.
- 8 Clean and inspect all parts for wear and damage, replace parts as necessary.

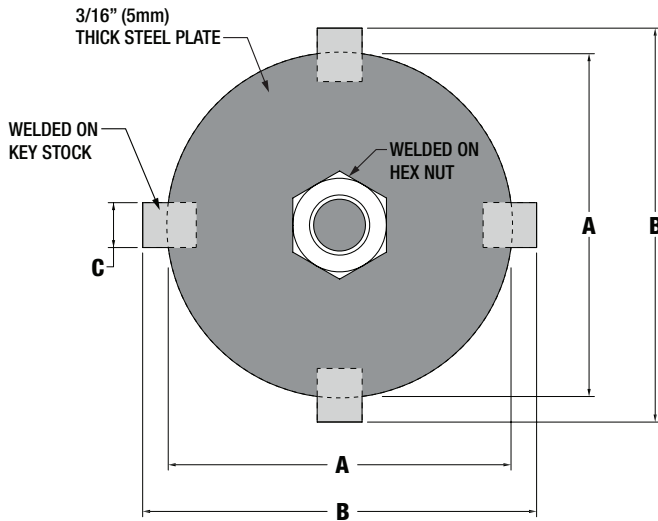
**Valve Disassembly Prep:**

- 1 Follow the Disassembly WARNING on Page 14 and relieve process pressure and drain the process fluid from inside and up/down stream of valve.
- 2 Place the valve assembly on a flat work surface that can support the weight or into a clamping device. **CAUTION:** When securing the valve body (Key 100) in a clamping device, it is important not to damage the gasket sealing surfaces.

**Seat Ring Removal (Valve):**

**NOTE:** As long as the valve body has been removed from the pipeline, the seat ring can be removed as part of maintenance without dismantling the rest of the valve assembly.

- 1 Follow the Disassembly WARNING on Page 14 and the Valve Assembly Prep above.
- 2 It is recommended that a special wrench be constructed to remove the seat ring retainer (Key 114). Similarly, seat ring installation will also require this wrench. Refer to Figure 28 and Table 5 for wrench construction dimensions.



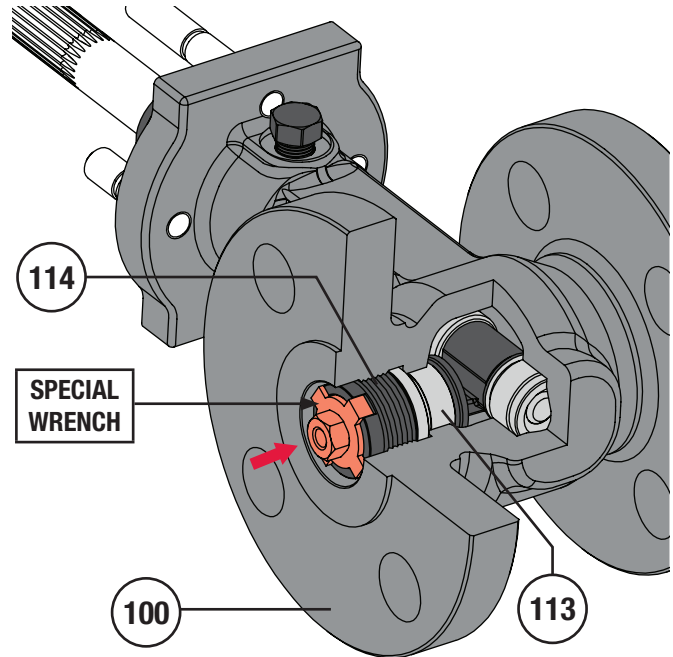
**Figure 28** Seat Ring Retainer Wrench Diagram

Table 5			
Seat Ring Retainer Wrench Dimensions			
Valve Size	Dimensions		
	A	B	C
1" NPS (25mm DN)	0.77" (19.5mm)	1.00" (25.4mm)	0.24" (6.1mm)
2" NPS (50mm DN)	1.40" (35.6mm)	1.87" (47.5mm)	0.30" (7.6mm)
3" NPS (80mm DN)	2.52" (64mm)	2.85" (72.4mm)	0.42" (10.7mm)
4" NPS (100mm DN)	3.23" (82mm)	3.68" (93.5mm)	0.42" (10.7mm)
6" NPS (150mm DN)	5.00" (127mm)	5.60" (142mm)	0.48" (12.2mm)

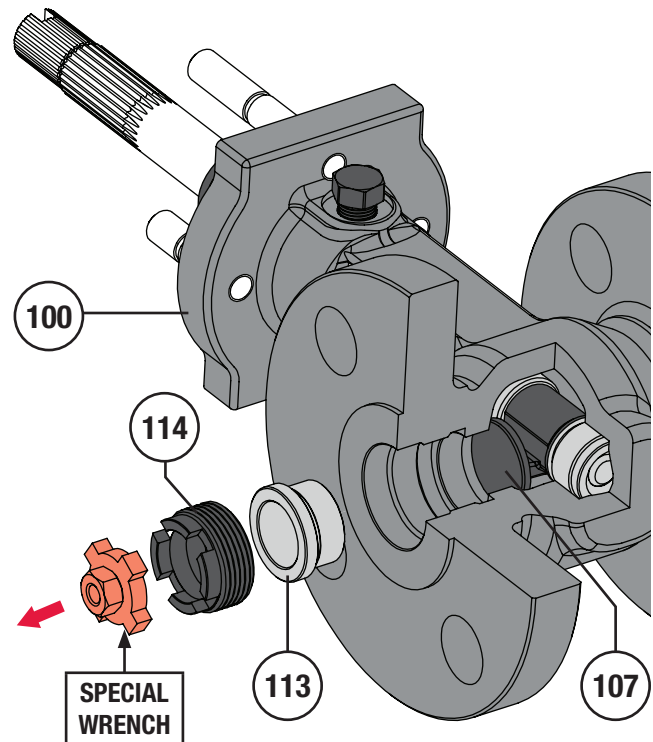
## Disassembly (Continued)

### Seat Ring Removal (Continued):

- Using the seat ring retainer wrench (Figure 28), loosen and then remove the seat ring retainer (Key 114) by rotating it counter-clockwise. Refer to Figures 29 & 30.
- Remove the seat ring (Key 113). Clean and inspect all parts for damage and wear, replace or repair parts as necessary. **NOTE:** Sometimes lapping can improve shut off and correct excessive seat leakage. Refer to LAPPING, Page 20 after valve disassembly has been completed.
- Refer to Step 1 of ASSEMBLY, Body Assembly (Page 22) and ASSEMBLY, Seat Ring Alignment (Page 24) for instructions to re-install the seat ring (Key 113).



**Figure 29** Seat Ring Retainer Wrench Placement

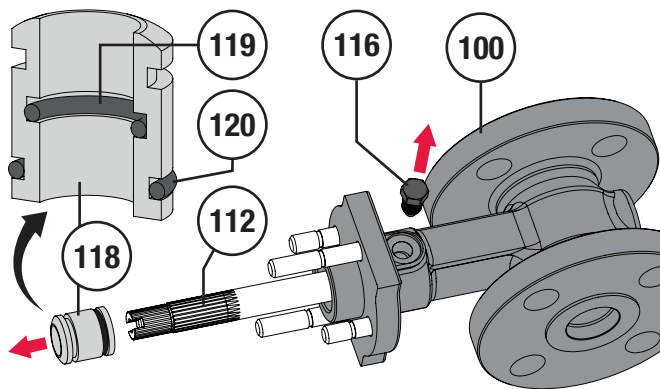


**Figure 30** Seat Ring Retainer Removal

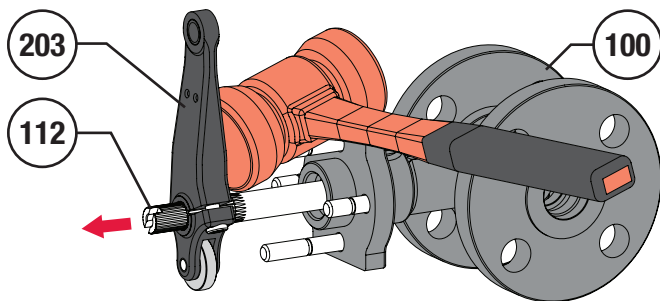
**Disassembly (Continued)**

**Shaft Removal (Valve):**

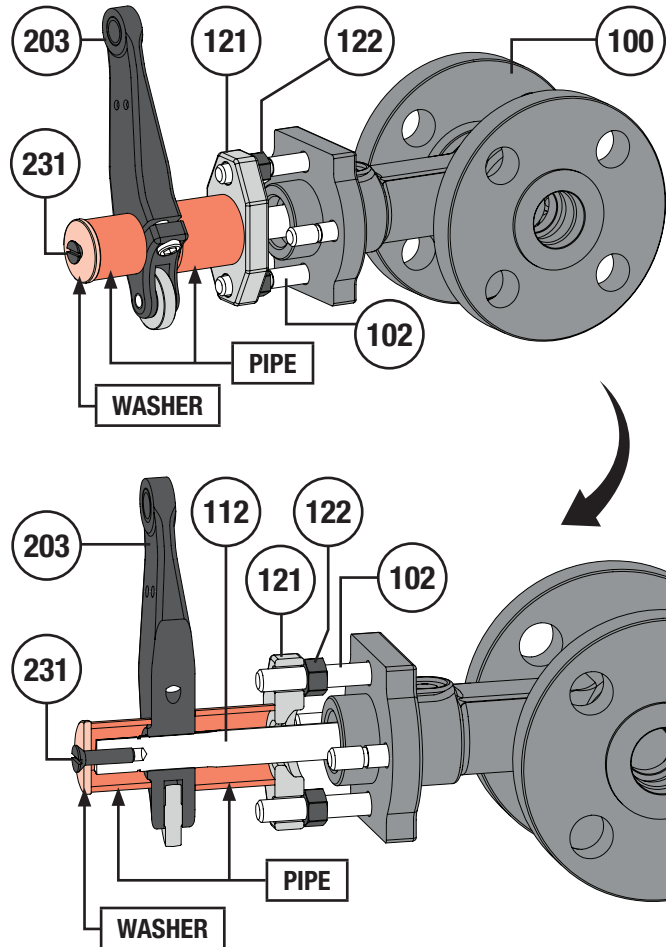
- 1 Remove the packing follower (Key 118). Carefully remove both the outer and inner o-rings (Keys 119 & 120) from the packing follower. Replace both o-rings.
- 2 Remove the safety pin (Key 116). **NOTE:** The safety pin prevents the shaft (Key 112) from being pulled out of the valve body (Key 100) when the yoke (Key 200) is removed or pushed out when the valve is pressurized.
- 3 Remove the shaft (Key 112). **CAUTION:** If the shaft cannot be easily pulled from the valve assembly, there are two recommended methods to aid in removal:
  - A Install the lever (Key 203) on to the splines of the shaft and tighten the lever cap screw (Key 206). Tap the lever with a rubber mallet as close to the shaft as safely possible to try to dislodge the shaft from the assembly.
  - B If tapping the lever with a mallet as described above proves to be ineffective, it may be necessary to construct an extraction tool made of the packing flange (Key 121), lever and pipe. Refer to Figure 33 for the extraction tool construction and operation diagram.



**Figure 31** Packing Follower / Safety Pin Removal



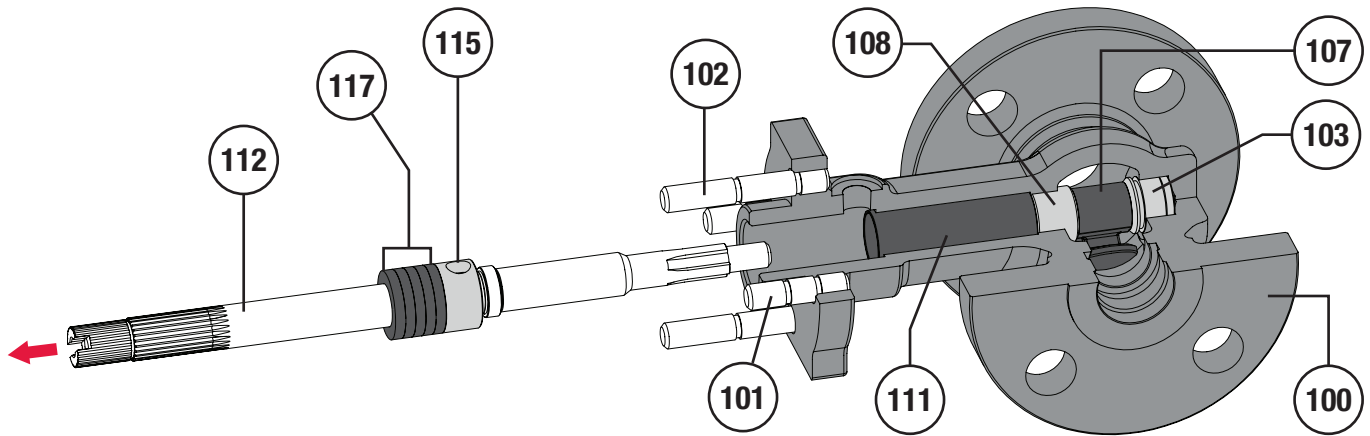
**Figure 32** Shaft Removal - Optional Method A



**CONSTRUCT THE JIG ABOVE. BY TIGHTENING THE PACKING NUTS (KEY 122) INTO THE PACKING FLANGE (KEY 121) EVENLY AND IN AN ALTERNATING FASHION, THE SHAFT (KEY 112) CAN BE PULLED OUT OF THE BODY. IT MAY BE NECESSARY TO STACK MORE THAN ONE WASHER DEPENDING ON VALVE SIZE.**

**Figure 33** Shaft Removal - Optional Method B

- 4 As the shaft (Key 112) is removed, internal parts will exit out with the shaft. The packing (Key 117) and packing box ring (Key 115) will be removed, the spacer (Key 111) and upper guide bushing/upper seal bushing (Key 108 or 109) may also come along.
- 5 Clean and inspect all parts for wear and damage, replace parts as necessary. All soft parts such as packing and o-rings must be replaced.

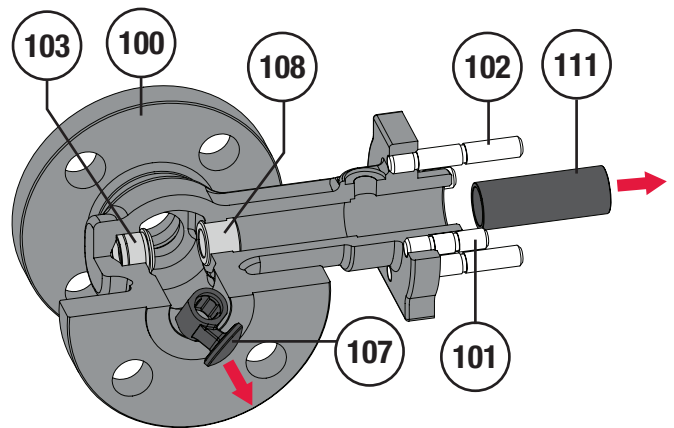


**Figure 34** Shaft Removal

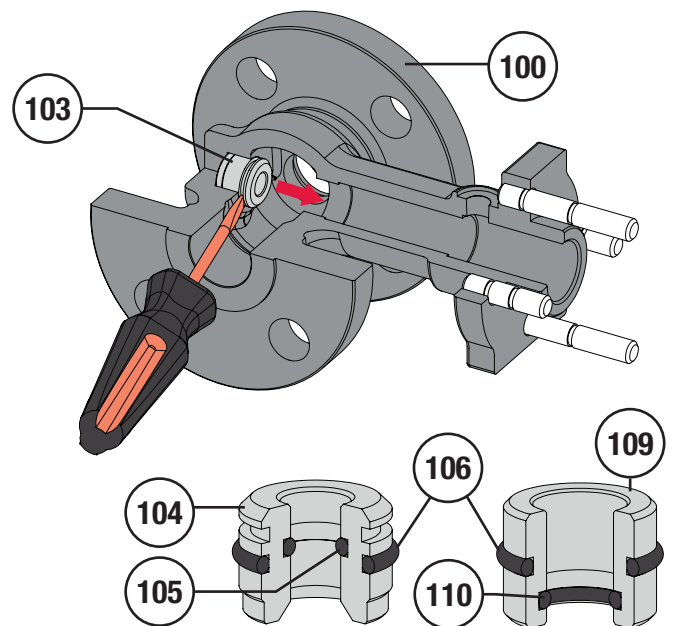
## Disassembly (Continued)

### Internal Parts Removal (Valve):

- 1 Separate the packing rings (Key 117) and packing box ring (Key 115) from the valve shaft (Key 112), be careful not to scratch the shaft.
- 2 Remove the spacer (Key 111) through the open end of the valve bonnet.
- 3 Remove the plug (Key 107) through the opposite body orifice from the seat ring (Key 113) placement. **CAUTION:** When removing any internal valve parts through a body orifice, care must be taken to avoid damaging the seating area in the valve body or seating surface of the plug.
- 4 Remove the upper guide bushing (Key 108) or upper seal bushing (Key 109) from the same body orifice as the plug (Key 107). The bushing may also be removed from the bonnet opening but it is much easier to remove through the body. **NOTE:** A seal bushing is the same as a guide bushing except with the addition of o-rings (Keys 106 & 110) to create a seal. These seals are designed for use with viscous fluids.
- 5 Remove the lower guide bushing (Key 103) or lower seal bushing (Key 104) through the same body orifice as the plug in Step 3. There is an extraction groove on the outer surface of the bushing, it may be necessary to pry the bushing out using this groove.
- 6 Clean and inspect all parts for wear and damage, replace parts as necessary. Pay special attention when inspecting all seating or sealing surfaces, including bushing contact surfaces inside the valve body. All soft parts such as packing, o-rings and soft seats must be replaced.



**Figure 35** Spacer and Plug Removal



**Figure 36** Lower Bushing Removal and Seal Detail

## Lapping

Expect a certain amount of leakage in valves with metal seats. In some cases where leakage has become excessive, lapping can improve sealing performance. Before performing the lapping process, insure all parts have been thoroughly cleaned and sealing surfaces are free of debris.

### **! WARNING**

- Soft seats (Key 513) can only be lapped to the valve body (Key 100). Never lap a soft seat to the valve plug (Key 107).
- Read the Warnings on Page 2.
- Always wear the appropriate personal protective equipment.
- Be very careful when applying the lapping compound, lapping compound is abrasive and can easily damage parts.
- Always thoroughly clean all parts when lapping is finished. All abrasive lapping compound must be removed from all parts before assembling a valve for service.

### Special Materials Required:

- 400 – 600 grit (fine grit) Loctite® Clover® compound (Key D)
- A rubber stopper (refer to Figure 39)

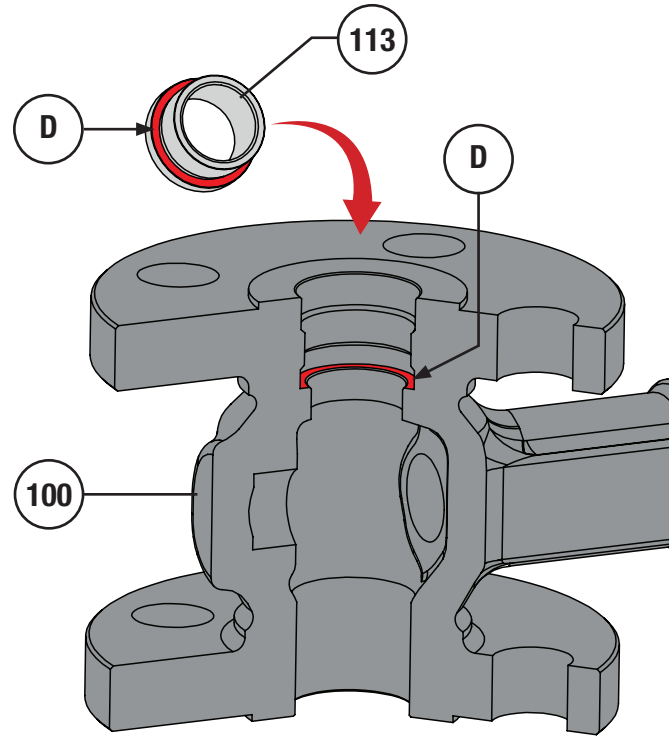
### Seat Ring-to-Body Lapping Procedure:

- 1 Carefully apply a small amount of fine grit Clover® compound (Key D) to the shoulder of the seat ring (Key 113) as shown in Figure 37.
- 2 Install the seat ring (Key 113) and lap gently by rotating the seat ring back and forth against the surface of the valve body (Key 100). Every so often, gently pick up the seat ring and rotate it 180° and continue lapping. **NOTE:** If require, for smaller sized valves, it may be possible to construct a tool out of a rubber stopper to hold the seat ring in place and make lapping action easier. Refer to Figure 38.
- 3 Remove the seat ring (Key 113) and thoroughly clean away the lapping compound from both the seat ring and valve body (Key 100). Reassemble the valve if ready.

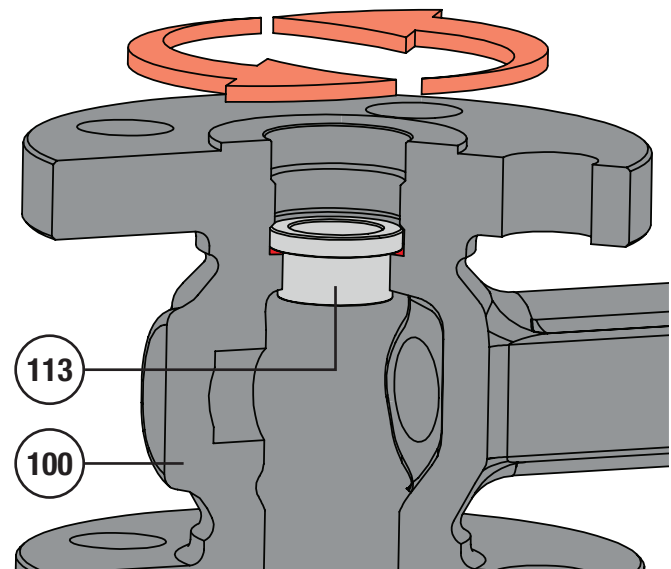
### Plug-to-Seat Ring Lapping Procedure:

- 1 Place the seat ring (Key 113) on a flat surface.
- 2 Carefully apply a small amount of fine grit Clover® compound (Key D) to the seating surface of the seat ring (Key 113) as shown in Figure 40.
- 3 Gently lap the plug (Key 107) against the seat ring (Key 113), turning and rotating the plug in all directions.

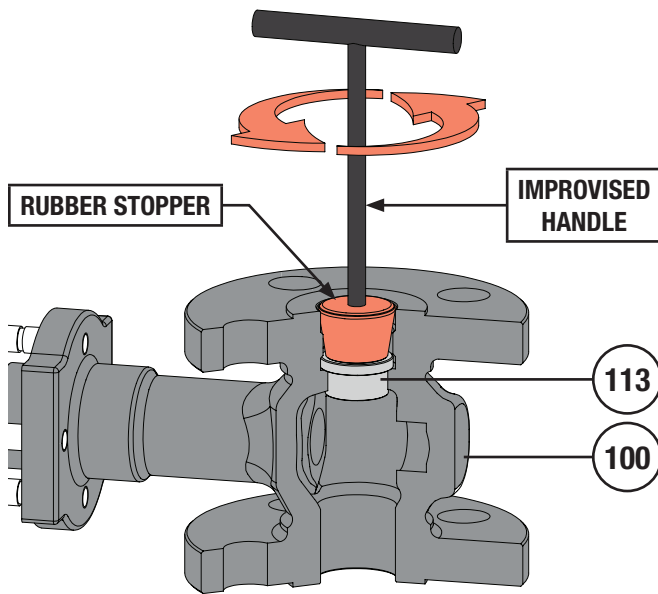
- 4 Finish lapping and thoroughly clean away the lapping compound from both the seat ring (Key 113) and plug (Key 107). Reassemble the valve if ready.



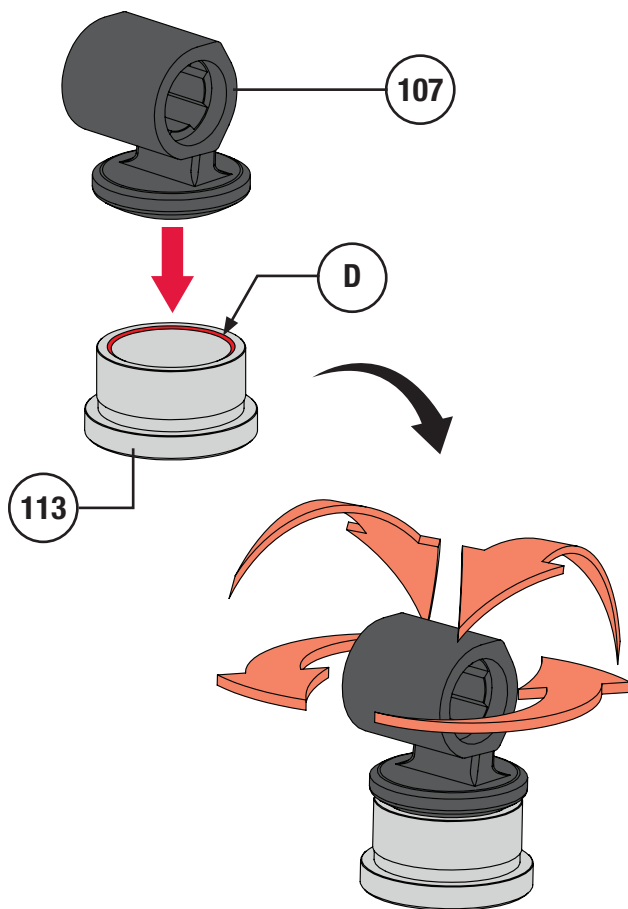
**Figure 37** Lapping Compound Placement



**Figure 38** Body-to-Seat Ring Lapping Action



**Figure 39** Lapping Using A Rubber Stopper



**Figure 40** Plug-to-Seat Ring Lapping Action

## Assembly

### **!** WARNING

#### Before You Begin:

- Read the Warnings on Page 2.
- Clean and inspect all parts.
- Replace or repair damaged parts. Replace all soft parts (Seals, o-rings, gaskets, grommet & shaft bearing).
- Always wear the appropriate personal protective equipment.
- Always use properly rated studs (Keys 101 & 102) and nuts (Key 122 & 123) approved by Dyna-Flo Control Valve Services with visible material grade identification marks. Service pressures and operation can lead to excessive stress on material unapproved for use in this particular service, property damage or personal injury may result.
- Do not use operating pressure that exceeds the Maximum Actuator Casing Pressure. Refer to Table 4.
- Property damage, environmental harm, and personal injury can result from the use of supply gas other than clean, non-corrosive, oil and moisture free air.
- Operating medium must be controlled and directed, use a loading device such as a 4-way switching valve or regulator. Refer to the appropriate instruction manual for the instrumentation used.

#### Special Tools Required:

- Deep Socket Wrench
- Seat Ring Retainer Wrench (Refer to Page 17).

#### Lubricants Required:

- Permatex® Nickel Anti-Seize or equivalent (Key A)
- Dow Corning Molykote® 5 or equivalent (Key B)
- 3M™ Rubber & Vinyl 80 Spray Adhesive or equivalent (Key E)
- Hylomar® PL32 Gasket Compound or equivalent (Key F)
- PTFE Thread Tape or equivalent (Key G)

### **!** WARNING

Do not lubricated parts intended for use in oxygen service with Dow Corning Molykote® 5. Fire, explosion, property damage or personal injury may result from applying Molykote® 5 lubrication to parts that will be installed into oxygen service.

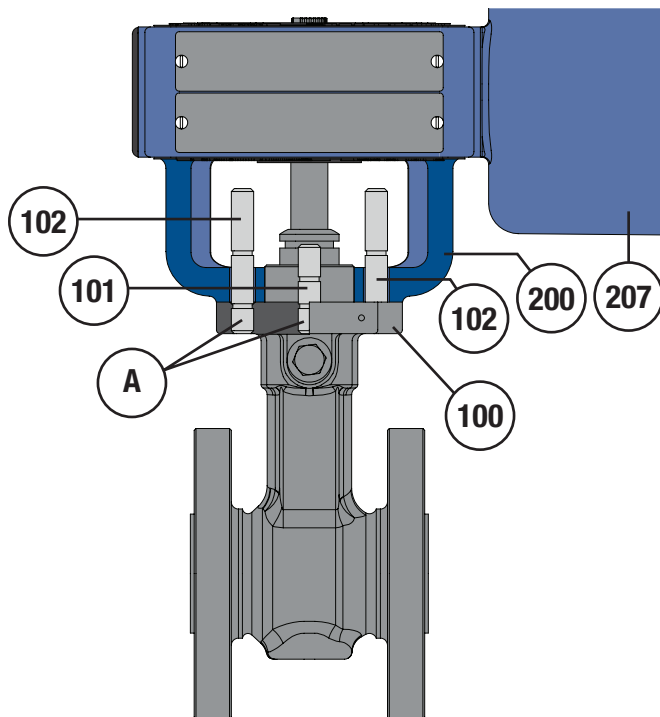
#### Stud Replacement (Valve):

- 1 If the studs (Keys 101 & 102) were damaged and removed, or never installed, apply Permatex® Nickel Anti-Seize (Key A) to the threads of the short end of the stud (or end without a material stamp).

**Assembly (Continued)**

**Stud Replacement (Continued):**

- Thread the studs (Keys 101 & 102) into the valve body (Key 100) nickel anti-seize coated end first, until they are completely threaded into the valve body. **NOTE:** Stud placement is dependant on where the window of the yoke (Key 200) is relative to the mounting pad of the body. Stud positions may need to be switched around if valve/actuator orientation has changed. Mounting studs (Key 101, short studs) should be installed so that they are easily accessed through the window of the yoke. Refer to Figure 41.



**Figure 41** Mounting/Packing Stud Placement

**Body Assembly (Valve):**

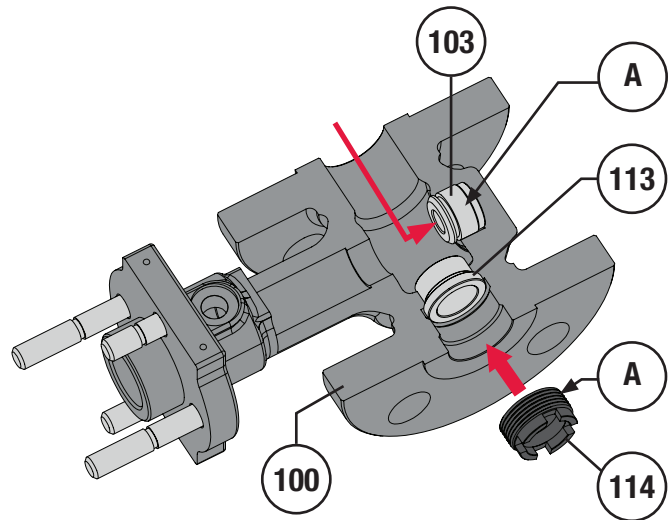
- Install the seat ring (Key 113). Apply a small amount of Permatex® Nickel Anti-Seize (Key A) to the threads of the seat ring retainer (Key 114), install the retainer hand tight only.

**⚠ WARNING**

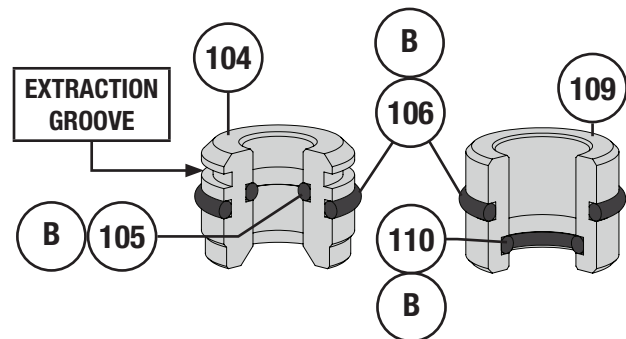
Do not tighten the seat ring retainer to the recommended torque specification at this time. Complete tightening of the seat ring retainer at this step can damage the plug (Key 107) or seat (Key 113).

- Flip the valve body (Key 100) so that the seat ring retainer (Key 114) is on the bottom side.

- Apply Permatex® Nickel Anti-Seize (Key A) to the lower guide bushing (Key 103) and install it into the valve body (Key 100) as shown in Figure 42. The extraction groove in the lower guide bushing or seal bushing must be visible. **NOTE:** Seal bushings (Keys 104 & 109) are equipped with two o-rings (Keys 105, 106 & 110). Apply Dow Corning Molykote® 5 (Key B) to the o-rings and install them in the upper and lower seal bushings, install the seal bushings the same as the guide bushings.

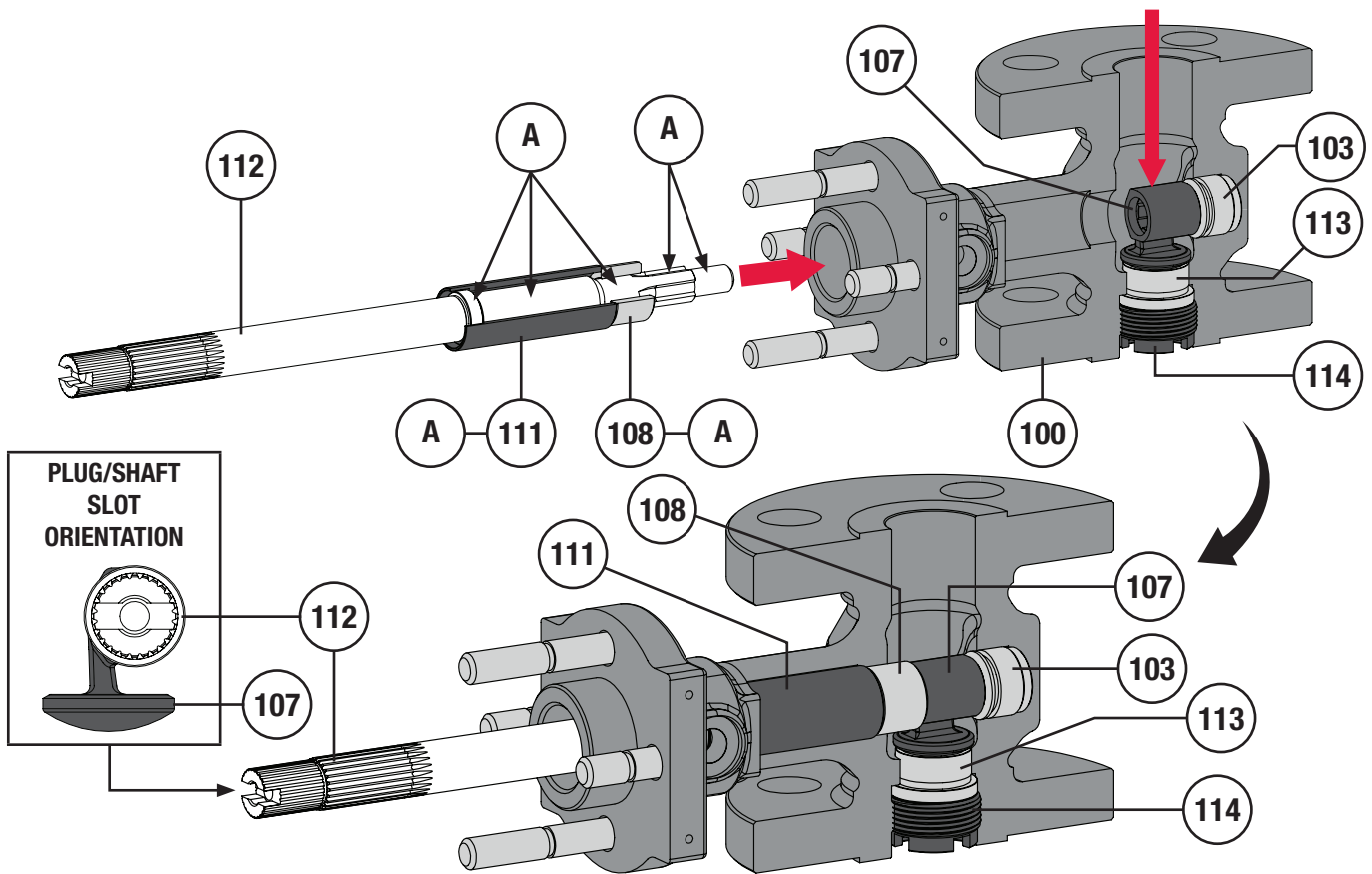


**Figure 42** Body Assembly - Steps 1 to 3



**Figure 43** Seal Bushing Detail

- Set the plug (Key 107) into the valve body (Key 100) so that it rests on the seat ring (Key 113). Refer to Figure 44.
- Apply Permatex® Nickel Anti-Seize (Key A) to the splines and lower half of the shaft (Key 112) as shown in Figure 44. Install the upper guide bushing or seal bushing (Key 108 or 109) and spacer tube (Key 111) on the shaft.
- Apply Permatex® Nickel Anti-Seize (Key A) to the outside surface of the upper bushing (Key 108 or 109) and spacer tube (Key 111). Install the shaft assembly as shown in Figure 44. **NOTE:** The slot in the end of the shaft should be orientated to indicate where the seating surface of the plug is located as shown.



**Figure 44** Valve Shaft Installation - Steps 4 to 6

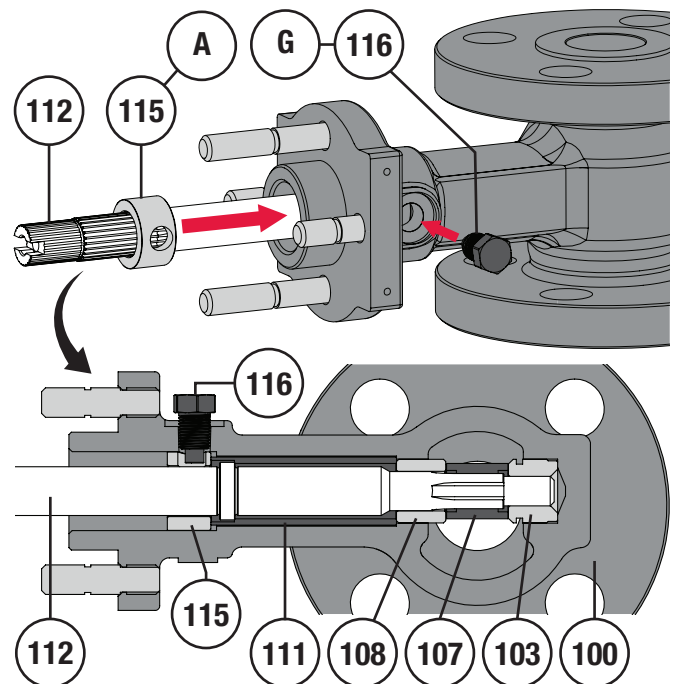
## Assembly (Continued)

### Body Assembly (Continued):

- 7 Apply Permatex® Nickel Anti-Seize (Key A) to the outside surface of the packing box ring (Key 115). Install the packing box ring, insert the side with the larger bevel into the bonnet bore first. Try to align the safety pin hole in the bonnet with that of the packing box ring. If the packing box ring is installed backwards, the safety pin holes in the bonnet and ring will not align. Refer to Figure 45.
- 8 Wrap PTFE Thread Tape (Key G) to the threads of the safety pin (Key 116) and install the safety pin and tighten completely.

### **!** WARNING

The safety pin is specifically designed and machined to be a safety device and cannot be substituted with a plug or cap screw. When completely tightened, the safety pin should engage the packing box ring (Key 115) but not touch the valve shaft (Key 112). Test the engagement by rotating the shaft and trying to pull the shaft out of the bonnet, the safety pin should allow the shaft to rotate freely but prevent blowout or removal.



**Figure 45** Packing Box Ring and Safety Pin Installation

**Assembly (Continued)**

**Body Assembly (Continued):**

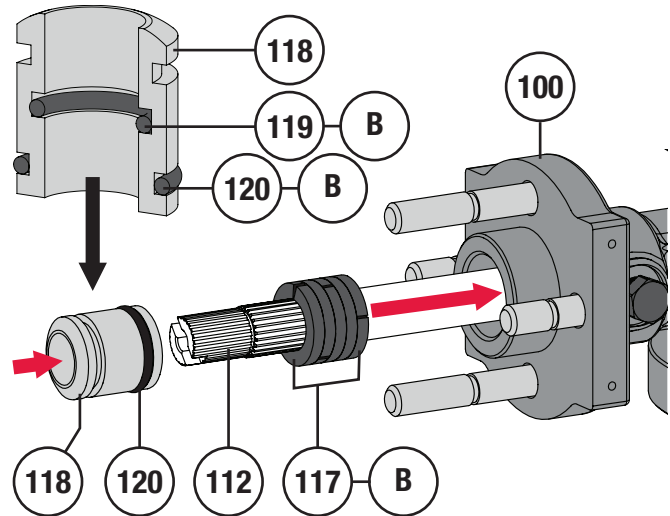
- Apply Dow Corning Molykote® 5 (Key B) to the packing rings (Key 117) and install them one-at-a-time so no air becomes trapped between rings. **NOTE:** Rings must be staggered so that splits in the rings do not overlap, rotate rings at least 120° from one another. 1" to 3" and 6" valves will have 5 rings, 4" will have 6 rings.

**! WARNING**  
Do not lubricated parts intended for use in oxygen service with Dow Corning Molykote® 5. Fire, explosion, property damage or personal injury may result from applying Molykote® 5 lubrication to parts that will be installed into oxygen service.

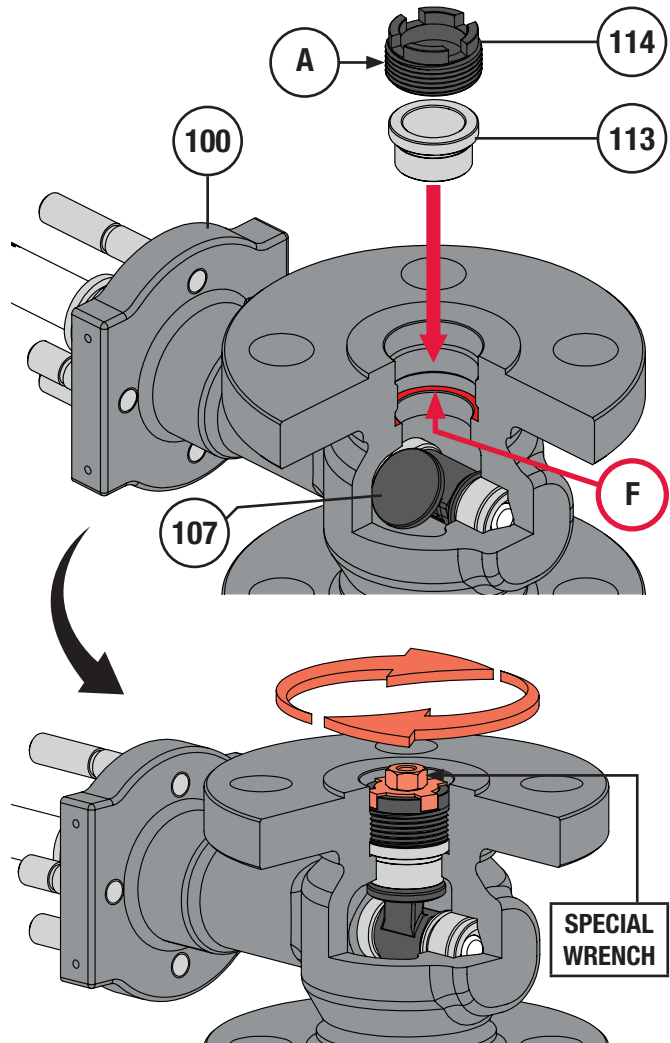
- Apply Dow Corning Molykote® 5 (Key B) to the packing follower o-rings (Keys 119 & 120) and install them into the packing follower (Key 118). Install the packing follower assembly as shown in Figure 46.

**Seat Ring Alignment (Valve):**

- If the valve assembly is still orientated with the seat ring (Key 113) facing down, flip the valve body so that the seat ring is accessible.
- If the seat ring (Key 113) and seat ring retainer (Key 114) were installed during Body Assembly (Step 1, Page 22), remove both the seat ring and retainer. **NOTE:** It is recommended that a special wrench be constructed to remove/install the seat ring retainer. Refer to Figure 28 and Table 5 on Page 17 for wrench construction dimensions.
- Rotate the shaft (Key 112) and move the valve plug (Key 107) to the open position.
- Apply a small amount of Hylomar® PL32 Gasket Compound (Key F) to the seat ring shoulder inside the valve body (Key 100). Follow the manufacturer's instructions for application and cure time.
- Install the seat ring (Key 113) and rotate the seat ring gently around the shoulder in the valve body to evenly distribute the gasket compound.
- Apply Permatex® Nickel Anti-Seize (Key A) to the threads of the seat ring retainer (Key 114), install the retainer hand tight only.
- Rotate the shaft (Key 112) so that the plug (Key 107) moves into the closed position with enough force to engaging and align with the seat ring (Key 113). **NOTE:** It may be necessary to make a handle out of the lever (Key 203) to help rotate the shaft. Refer to DISASSEMBLY, Shaft Removal, Step 3A on Page 18 for instructions.



**Figure 46** Packing and Packing Follower Installation



**Figure 47** Seat Ring Alignment/Installation

## Assembly (Continued)

### Seat Ring Alignment (Continued):

- Using the special wrench, tighten the seat ring retainer (Key 114) to the proper torque specification listed in Table 6.

Valve Size	Minimum Torque	
	lbf-ft.	N·m
1" NPS (25mm DN)	60	81
2" NPS (50mm DN)	100	136
3" NPS (80mm DN)	290	393
4" NPS (100mm DN)	363	492
6" NPS (150mm DN)	825	1119

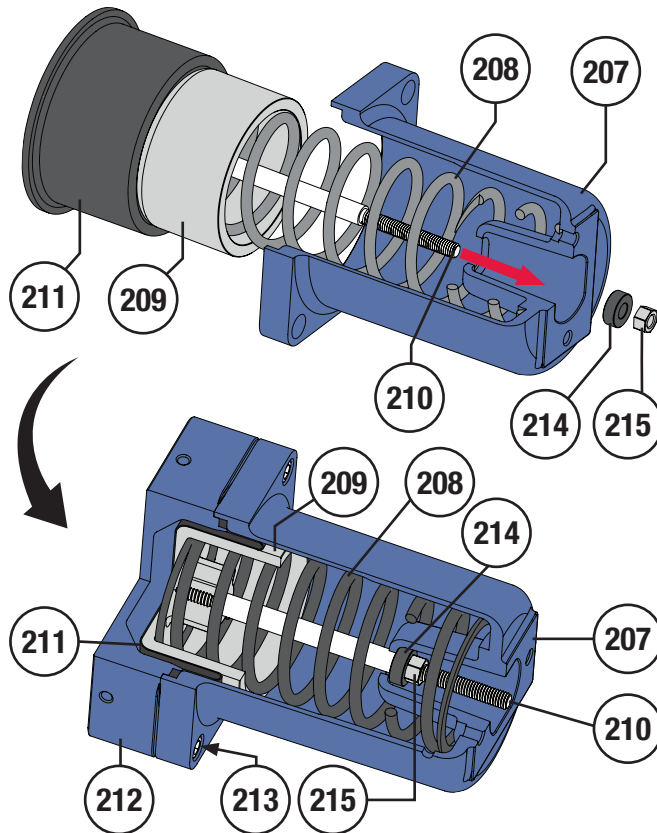


Figure 48 Spring Barrel Sub-Assembly

### Spring Barrel Assembly (Actuator):

- Set the spring (Key 208) into the spring barrel (Key 207).
- The piston stem (Key 210) and piston (Key 209) are press fit at factory and should be treated as a single part. Install the piston/piston stem into the spring barrel (Key 207) as shown in Figure 48.
- Slide the stem travel stop (Key 214) on to the piston stem (Key 210). Using a deep socket, completely tighten the locknut (Key 215) on the piston stem, it will hold the travel stop in place.

**! WARNING**  
The spring (Key 208) will be under compression once the locknut (Key 215) has been completely threaded on to the piston stem (Key 210). Use caution working around a compressed spring.

- If the diaphragm (Key 211) was replaced, refer to MAINTENANCE, Diaphragm Maintenance, beginning at Step 4 on Page 9 for diaphragm installation instructions.
- Complete Steps 7 and 8 of the Diaphragm Maintenance instructions on Page 10 and finish the spring barrel sub-assembly.

### Yoke-to-Valve Mounting (Actuator):

- Install the grommet (Key 201) and shaft bearing (Key 202) in the yoke (Key 200) as shown in Figure 49. **NOTE:** The bearing should install easily, ensure the yoke is clean and do not use excessive force installing the bearing.
- Close the valve. Ready the lever assembly (Keys 203 & 206) and packing flange (Key 121) for installation. **NOTE:** The lever and packing flange must be installed over the valve shaft (Key 112) as the valve shaft travels through the yoke (Key 200). Figure 50.

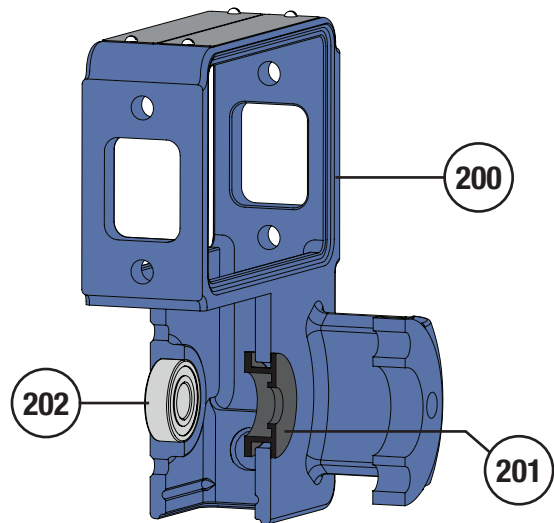
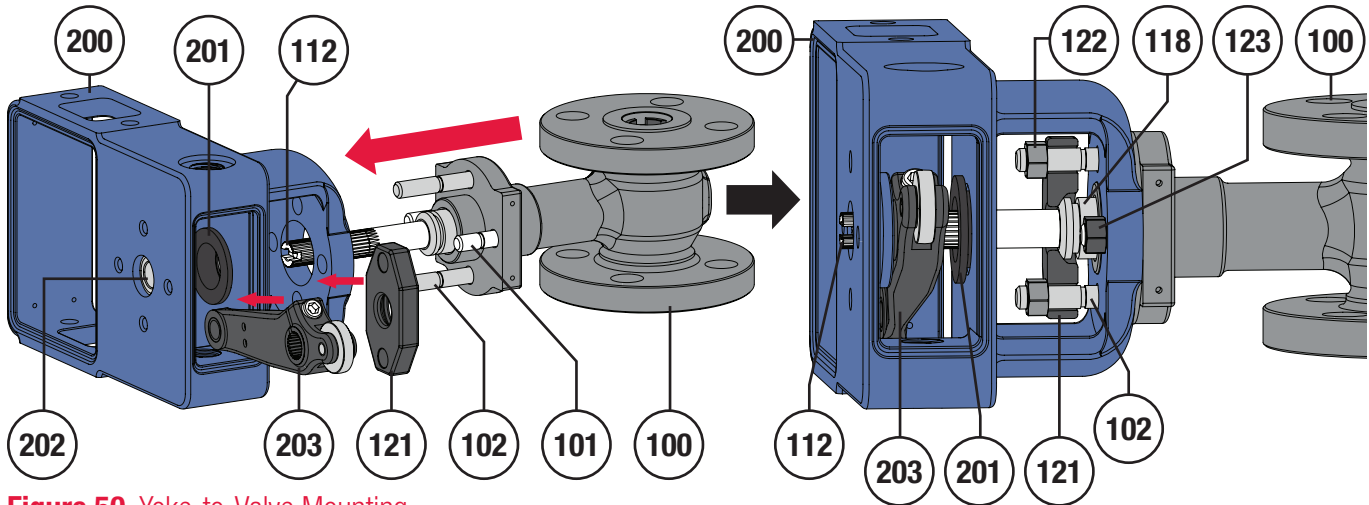


Figure 49 Grommet/Shaft Bearing Installation



**Figure 50** Yoke-to-Valve Mounting

**Assembly (Continued)**

**Yoke-to-Valve Mounting (Continued):**

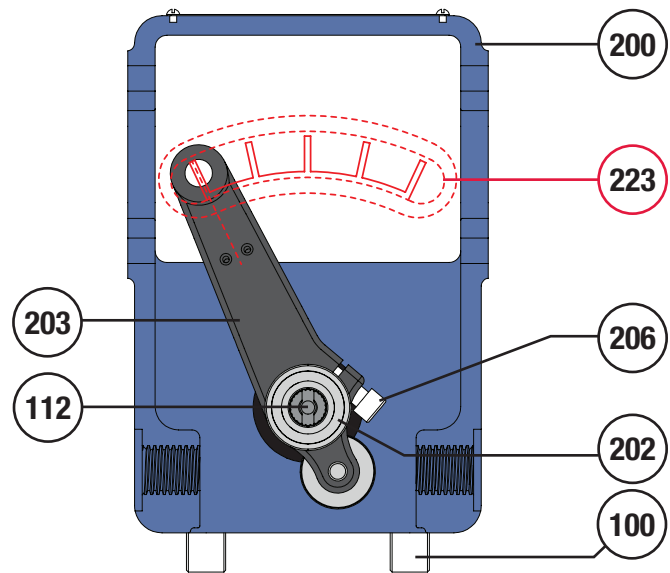
**! WARNING**

The position of the valve body (Key 100) can be rotated around the mounting pad of the actuator yoke (Key 200) and the mounting location of the spring barrel sub-assembly can be moved to the other side of the actuator yoke. Changing the actuator action or position of the valve body may severely impact the conditions of operation for this product, and it is recommended that the valve and actuator be re-sized should any changes to the original assembly orientations be made. The mounting studs (Keys 101 & 102) will also need to be swapped should the orientation of the valve body change, refer to ASSEMBLY, Stud Replacement on Page 21 for instructions.

- 3 Mount the yoke (Key 200) to the valve as shown in Figure 50, installing the packing flange (Key 121) and lever (Key 203) as the yoke is mounted. Secure the yoke to the valve body (Key 100) by installing the mounting nuts (Key 123). **NOTE:** Orientate the lever on the shaft (Key 112) using any marks that might have been made during disassembly. If no alignment marks were made, it may be necessary to temporarily install the front cover (Key 223) to utilize the travel scale. With the valve in the closed position, the closed indicator line on the travel scale should run roughly between the 2 travel indicator mounting holes on the lever. Refer to Figure 51 and 54.

**! WARNING**

If the lever (Key 203) does not properly align with the travel scale when the valve is in the closed position as shown in Figure 54 (UNACCEPTABLE ALIGNMENT), then the lever is misaligned on the shaft (Key 112). An unacceptably aligned lever will cause operation errors. It will be necessary to separate the valve from the actuator again and reposition the lever on the shaft.



**Figure 51** Lever Position Example

- 4 When the packing flange (Key 121) is properly installed over the packing follower (Key 118), tighten the packing nuts (Key 122) evenly and in an alternating pattern until hand tight. Once hand tight, tighten each packing nut another half turn.
- 5 For optimal operation it is recommended that the lever (Key 203) be used to pull the valve shaft (Key 112) as far as possible into the actuator yoke (Key 200). Slide the lever towards the valve body and tighten the cap screw (Key 206). With the lever tightened, pull the lever into the shaft bearing (Key 202) as much as possible.
- 6 Loosen the lever cap screw (Key 206) and slide the lever (Key 203) back so that it shoulders against the shaft bearing (Key 202). Re-tighten the lever cap screw.

## Assembly (Continued)

### Yoke-to-Valve Mounting (Continued):

- 7 It is recommended that an alignment mark be made on the clevis (Key 218) before the spring barrel assembly is installed. With the valve in the closed position, place the clevis over the lever (Key 203) so the holes are aligned (it may help to temporarily install the clevis pin (Key 219). Mark a line on the clevis where the clevis lines up with the edge of the yoke window as shown in Figure 52. Remove the clevis and proceed to Spring Barrel Assembly Installation.

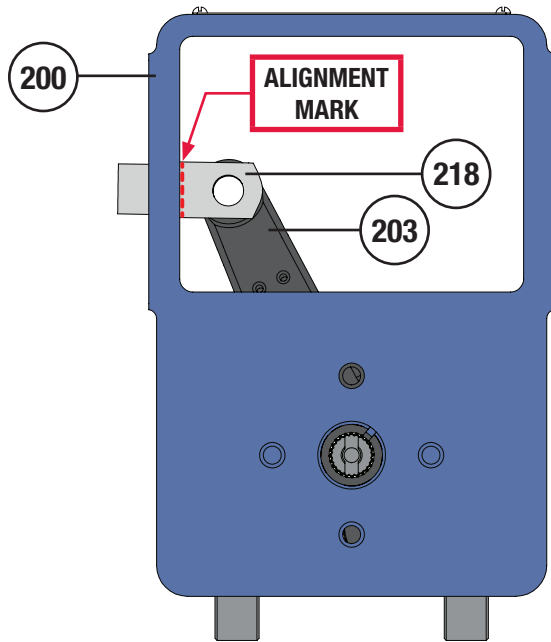


Figure 52 Clevis Alignment Mark

### Spring Barrel Assembly Installation (Actuator):

The mounting position of the spring barrel assembly on the yoke (Key 200) will change the action of the actuator. The actuator will be spring-to-close or spring-to-open depending on which side of the yoke the spring barrel is mounted relative to valve position. Refer to Figure 2 for mounting positions.

#### **! WARNING**

The actuator spring (Key 208) is stored under compression inside the spring barrel (Key 207). Changing the actuator action or position of the valve body may severely impact the conditions of operation for this product, and it is recommended that the valve and actuator be re-sized should any changes to the original assembly orientation be made.

- 1 Read the Before You Begin Safety Warning on Page 21. Move the lever (Key 203) to a neutral position away from where the spring barrel assembly will be mounted.
- 2 Secure the spring barrel assembly to the appropriate yoke (Key 200) mounting pad using the cap screws (Key 216) and lock washers (Key 217), tighten the cap screws completely. Refer to Figure 53. **NOTE:** When mounting the spring barrel assembly, it is important to consider the placement of vent holes and tubing paths to reconnect instrumentation.
- 3 Proceed to the Actuator Stem Adjustment section on Page 28 to complete the connection between the lever (Key 203) and piston stem (Key 210).

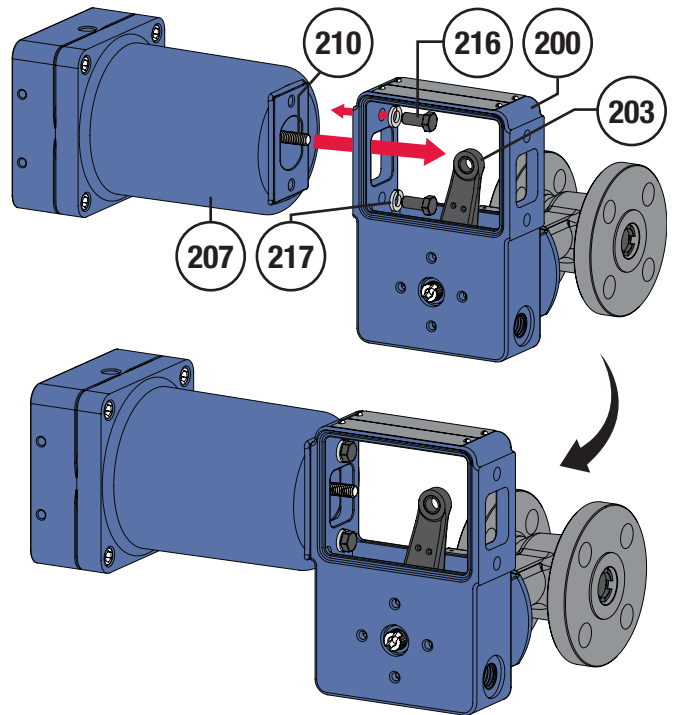


Figure 53 Spring Barrel Assembly Installation

## Actuator Stem Adjustment

### **! WARNING**

#### Before You Begin:

- Read the Warnings on Page 2. Use appropriate safe work practices and lock out procedures.
- Relieve process pressure and drain the process fluid from up and down stream of valve.
- Sudden movement of actuator can cause damage or injury. Remove any operating medium to the actuator and remove any tension applied by either a travel stop or handwheel before performing any work. To adjust the travel stop and handwheel, loosen Keys 302 and 401, refer to Figure 5.
- Always wear the appropriate personal protective equipment.
- Do not use operating pressure that exceeds the Maximum Actuator Casing Pressure. Refer to Table 4.
- Property damage, environmental harm, and personal injury can result from the use of supply gas other than clean, non-corrosive, oil and moisture free air.

If an Actuator Stem Adjustment needs to be performed on a complete DF400 assembly, follow Steps 1 to 8 of the Valve/Actuator Separation instructions on Page 10. The clevis (Key 218) will also need to be loosened and adjusted, proceed to Step A below.

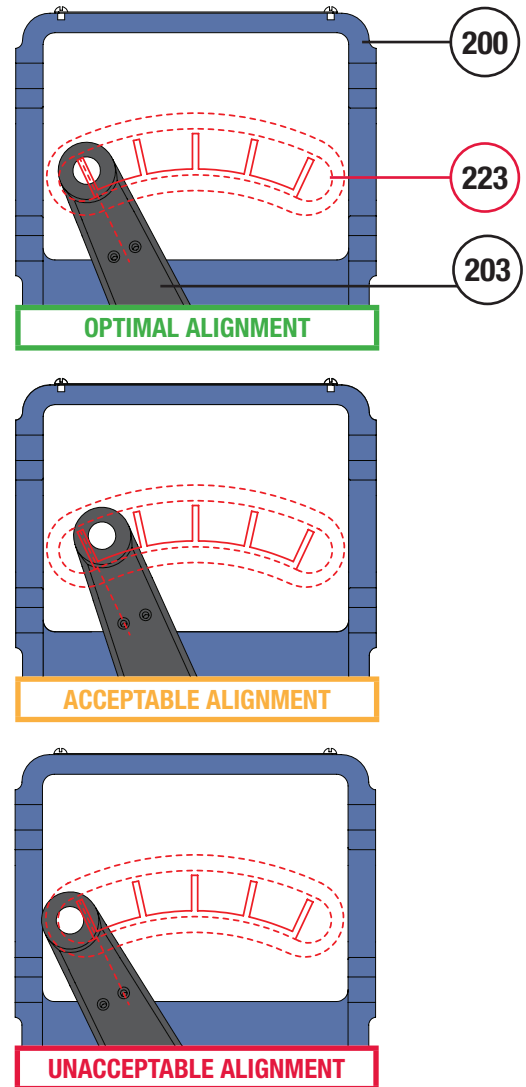
If Step 3 of ASSEMBLY, Spring Barrel Assembly Installation was just completed, proceed to Step 1 below.

**A** Move the lever (Key 203) as far away from the clevis (Key 218) as possible. Connect a regulated air supply to the supply port of the diaphragm case (Key 212) and supply enough air to move the piston stem (Key 210) to access the clevis locknut (Key 215) and clevis. Loosen the locknut and adjust the clevis back.

- 1 Place the valve into the closed position by manually moving the lever (Key 203).
- 2 Temporarily install the front cover (Key 223), use the travel scale to verify that the lever (Key 203) is aligning with the closed position on the travel scale. Refer to Figure 54 for proper lever placement.

### **! WARNING**

If the lever (Key 203) does not properly align with the travel scale when the valve is in the closed position as shown in Figure 54 (UNACCEPTABLE ALIGNMENT), then the lever is misaligned on the shaft (Key 112). An unacceptably aligned lever will cause operation errors. It will be necessary to separate the valve from the actuator and reposition the lever on the shaft. Refer to Valve/Actuator Separation on Page 10 and ASSEMBLY, Yoke-to-Valve Mounting on Page 25 for instructions on removing and re-installing the lever.



**Figure 54** Proper Lever Alignment

### Air-to-Open / Spring-to-Close:

- 1 Move the lever (Key 203) to a neutral position.
- 2 Connect a regulated air supply to the supply port of the diaphragm case (Key 212) and supply enough air to move the piston stem (Key 210) enough to install the clevis locknut (Key 215) and clevis (Key 218), or to loosen the clevis locknut. Vent the supply air from the actuator.
- 3 Adjust the clevis (Key 218) so that it is aligned to the yoke with any marks made during disassembly or from Step 7 of ASSEMBLY, Yoke-to-Valve Mounting on Page 27. **NOTE:** If no prior marks were made, it will be necessary to mark a line on the clevis as described in Step 7 of Yoke-to-Valve Mounting to be able to verify actuator stem travel in the next step.

## DF400 Actuator Bench Set Loading Pressures

Actuator Size	Bench Set Loading Pressure			
	Lower Bench Set		Upper Bench Set	
	PSIG	BARG	PSIG	BARG
4-1/2" (114mm)	7	0.48	15	1.03
6" (152mm)	7	0.48	15	1.03
7" (177mm)	7	0.48	24	1.65

## Actuator Stem Adjustment (Continued)

## Air-to-Open / Spring-to-Close (Continued):

- 4 Gradually apply supply air to actuator until the Lower Bench Set loading pressure from Table 7 is reached. The clevis (Key 218) should move approximately 1/4" (0.25mm) for all sizes when the appropriate amount of supply air is applied. Hold the initial set loading pressure while adjusting the clevis and lever (Key 203).

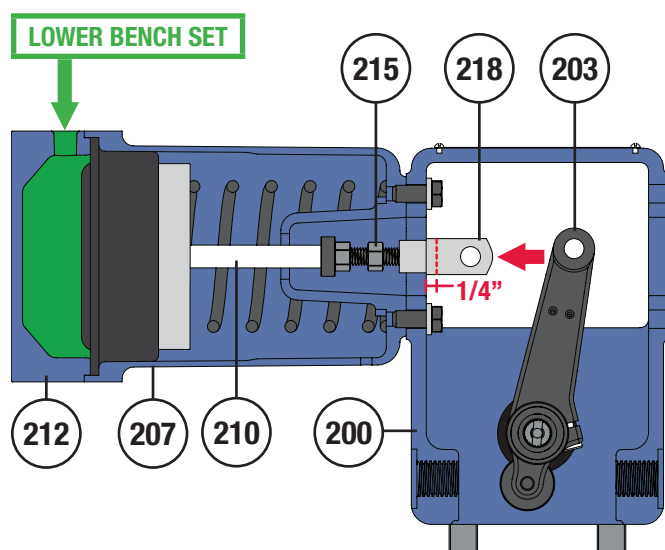


Figure 55 Air-to-Open Lower Bench Set

- 5 The holes of the clevis (Key 218) and lever (Key 203) should align when the Lower Bench Set is applied and the valve is completely closed. Adjust the position of the clevis until the clevis pin (Key 219) can be installed through the clevis and lever with the Lower Bench Set pressure applied.
- 6 Apply the Upper Bench Set loading pressure as listed in Table 7 and verify that the valve and lever (Key 203) are in the fully open position. It may be necessary to temporarily install the front cover (Key 223) and travel scale. Install the clevis pin (Key 219).

- 7 Tighten the clevis locknut (Key 215) into the clevis (Key 218).
- 8 Install the clevis clips (Key 220) as shown in Figure 59.
- 9 Relieve supply pressure to the actuator and cycle the valve and actuator a few times to check for proper operation.
- 10 Reinstall the travel indicator (Key 221) using the machine screws (Key 222). **NOTE:** The position of the travel indicator may need to be adjusted slightly to align with the travel scale on the front cover (Key 223) once installed. Refer to Figure 60.
- 11 Reinstall the covers (Keys 223, 224, 227, 228, 229 & 230). Refer to Figures 10, 21 & 22 for cover plate placements.
- 12 If a handwheel or travel stop is required, refer to the Handwheel or Travel Stop Installation instructions on Page 31.

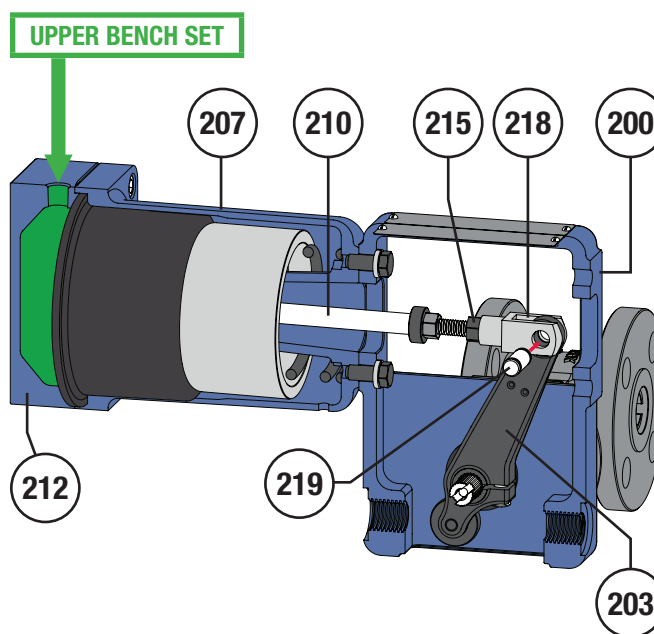
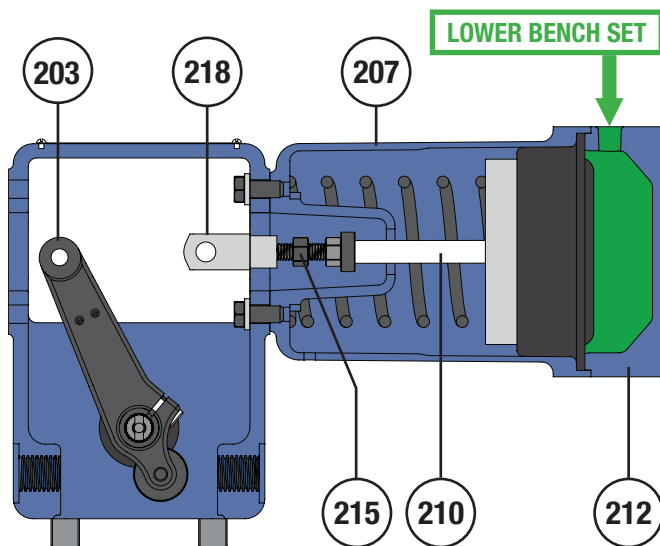


Figure 56 Air-to-Open Upper Bench Set

**Actuator Stem Adjustment (Continued)**

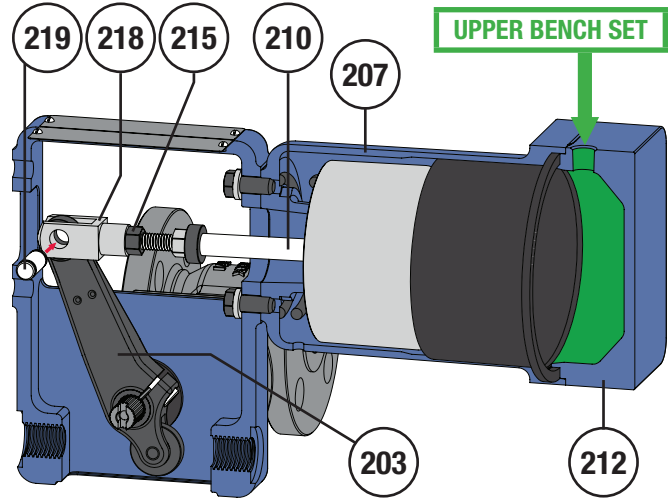
**Air-to-Close / Spring-to-Open:**

- 1 Move the lever (Key 203) to the closed position.
- 2 Connect a regulated air supply to the supply port of the diaphragm case (Key 212) and supply enough air to move the piston stem (Key 210) enough to install the clevis locknut (Key 215) and clevis (Key 218), or to loosen the clevis locknut.
- 3 If alignment marks were made during disassembly or from Step 7 of ASSEMBLY, Yoke-to-Valve Mounting on Page 27, then vent the supply air from the actuator. Adjust the clevis (Key 218) so that it is aligned to the yoke with any of those alignment marks.
- 4 Gradually apply supply air to actuator until the Upper Bench Set loading pressure from Table 7 is reached. The clevis (Key 218) should move to meet the lever (Key 203) and the hole in the clevis should align with the hole in the lever. If the holes do not align, continue to vent supply air and adjust the clevis as needed.
- 5 Install the clevis pin (Key 219).
- 6 Tighten the clevis locknut (Key 220) into the clevis (Key 218).
- 7 Install the clevis clips (Key 220) as shown in Figure 59.
- 8 Relieve supply pressure to the actuator and cycle the valve and actuator a few times to check for proper operation.
- 9 Reinstall the travel indicator (Key 221) using the machine screws (Key 222). **NOTE:** The position of the travel indicator may need to be adjusted slightly to align with the travel scale on the front cover (Key 223) once installed. Refer to Figure 60.

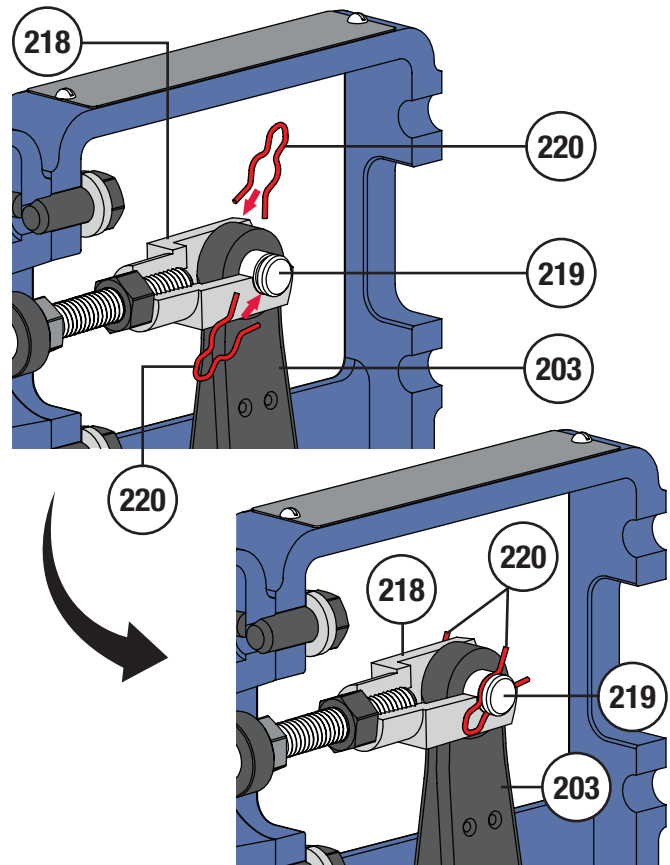


**Figure 57** Air-to-Close Lower Bench Set

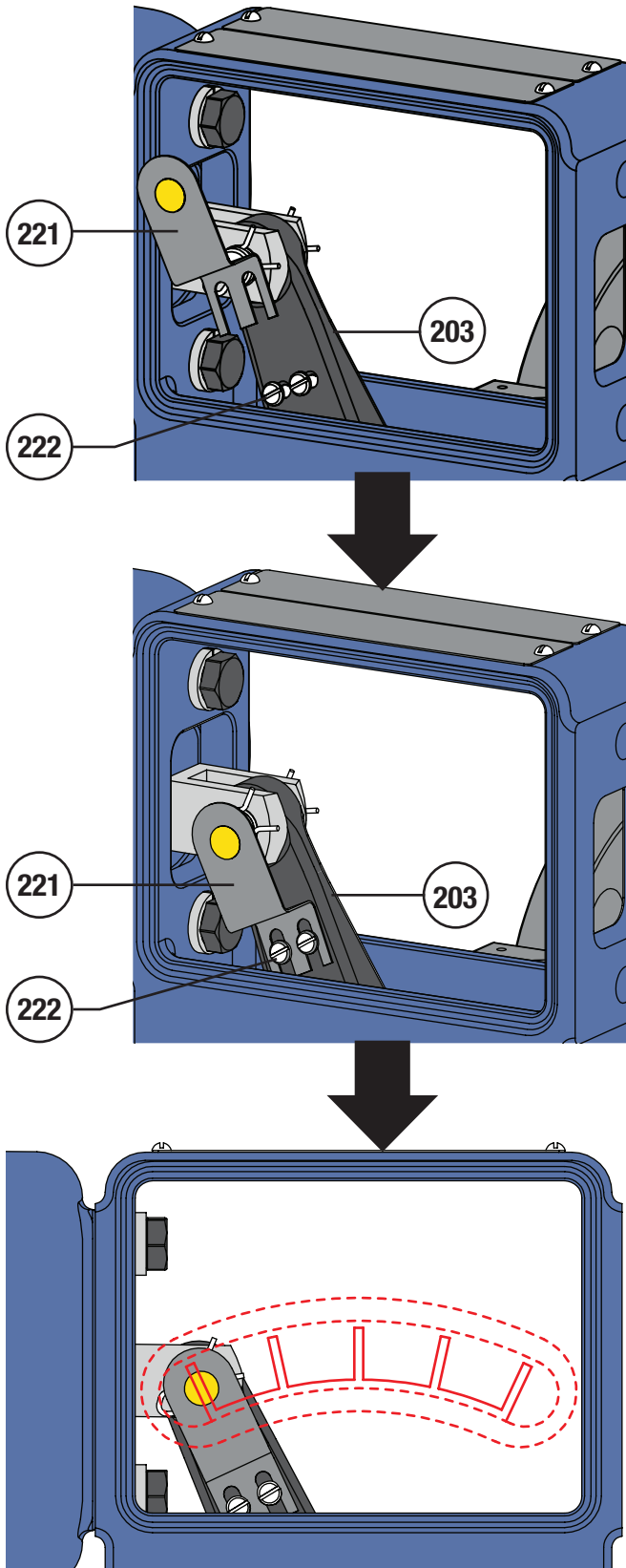
- 10 Reinstall the covers (Keys 223, 224, 227, 228, 229 & 230). Refer to Figures 10, 21 & 22 for cover plate placements.
- 11 If a handwheel or travel stop is required, refer to the Handwheel or Travel Stop Installation instructions on Page 31.



**Figure 58** Air-to-Close Upper Bench Set



**Figure 59** Clevis Clip Installation Detail



**Figure 60** Travel Indicator Installation

## Travel Stop and Handwheel Installation

### **! WARNING**

Handwheels are always installed to mimic air action of the actuator and oppose spring force acting on the lever (Keys 203 & 206). Refer to Figures 5 & 12 for correct handwheel positioning. Travel stops (Key 400) may be installed where needed.

### **! WARNING**

#### **Before You Begin:**

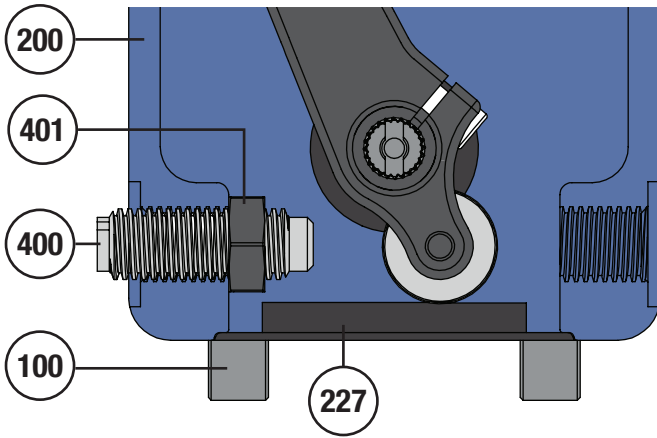
- Read the Warnings on Page 2.
- Sudden movement of actuator can cause damage or injury. Remove any operating medium to the actuator before performing any work. Always be aware of dangerous pinch points.
- Use safe work practices and lock out procedures before working on any equipment.
- Always wear the appropriate personal protective equipment.

#### **Travel Stop:**

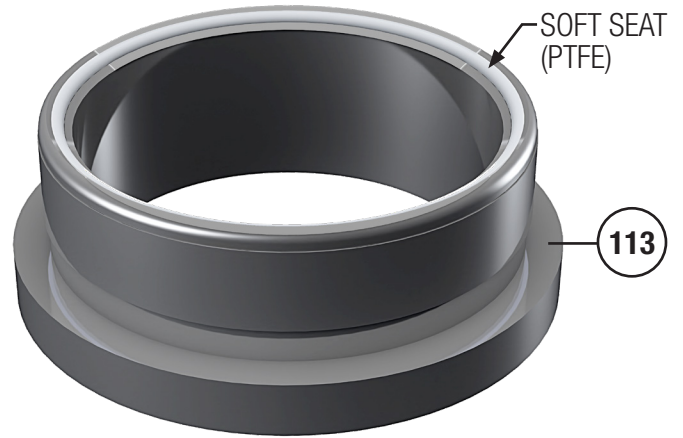
- 1 Use a large flat head screw driver and remove the thread plug (Key 229) from the yoke (Key 200). Refer to Figure 22 on Page 15.
- 2 Thread the locknut (Key 401) on to the travel stop (Key 400) and install the travel stop assembly into the yoke (Key 200). Refer to Figure 20 on Page 14. **NOTE:** Some sizes of actuator have a locknut that must be installed on the inside of the yoke. To install these travel stops, it will be necessary to remove the bottom cover (Key 227, Figure 10, Page 11) and thread the travel stop through the yoke into the locknut on the other side. Refer to Figure 61 on Page 32.
- 3 Position the travel stop (Key 400) as desired and lock it in place using the locknut (Key 401). Reinstall any covers.

#### **Handwheel:**

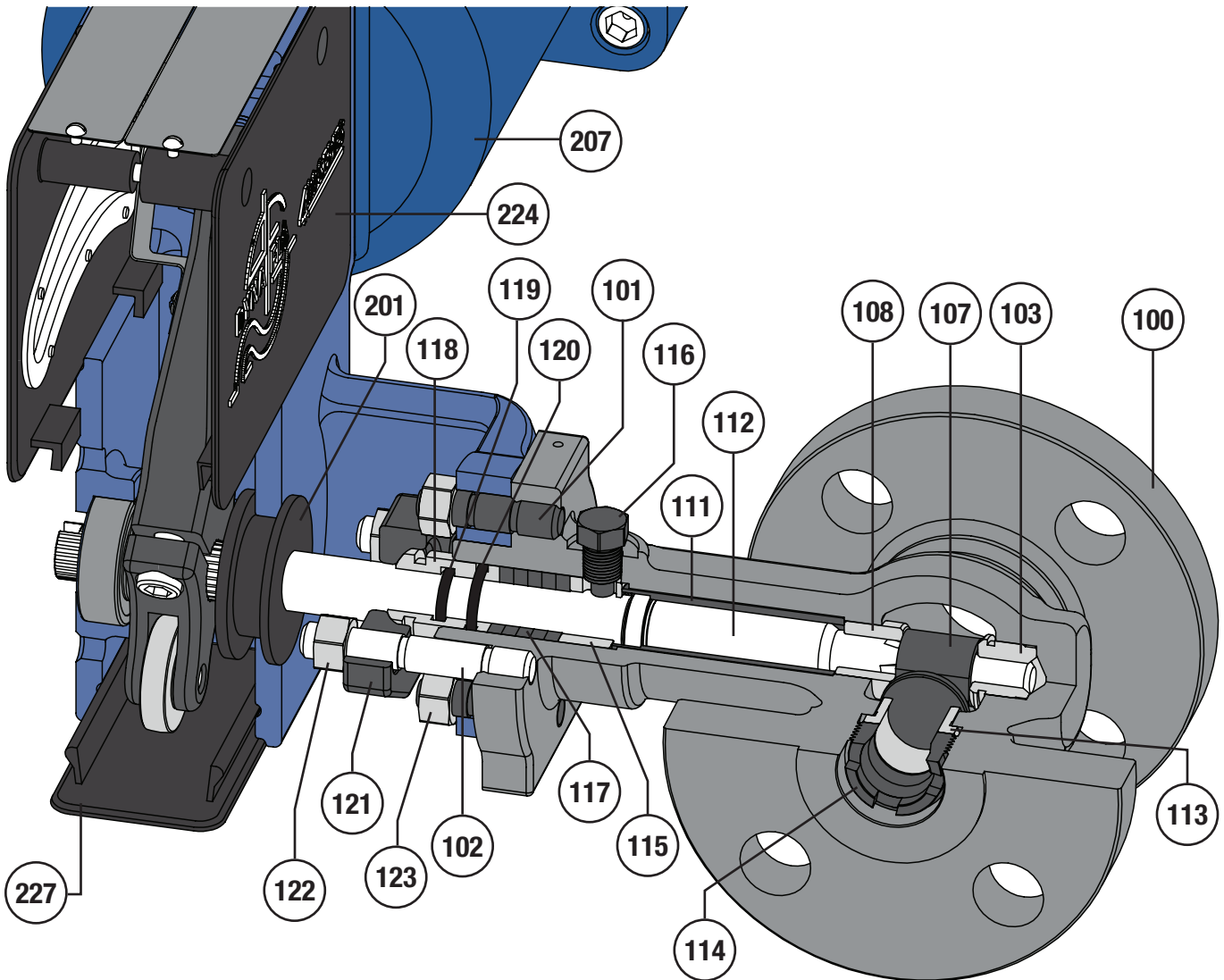
- 1 Use a large flat head screw driver and remove the thread plug (Key 229) from the yoke (Key 200). Refer to Figure 22 on Page 15.
- 2 Remove the bottom cover (Key 227). Refer to Figure 10 on Page 11.
- 3 Install the handwheel stem assembly (Keys 300, 301, 302, 305 & 306) into the yoke (Key 200) as shown in Figure 10.
- 4 Install washer (Key 303) onto the handwheel stem (Key 301) and secure the assembly in place by installing the E-clip (Key 304) into the groove of the handwheel stem.
- 5 Adjust the handwheel as desired and lock it in place by turning the handwheel lock (Key 302) into the yoke. Reinstall any covers.



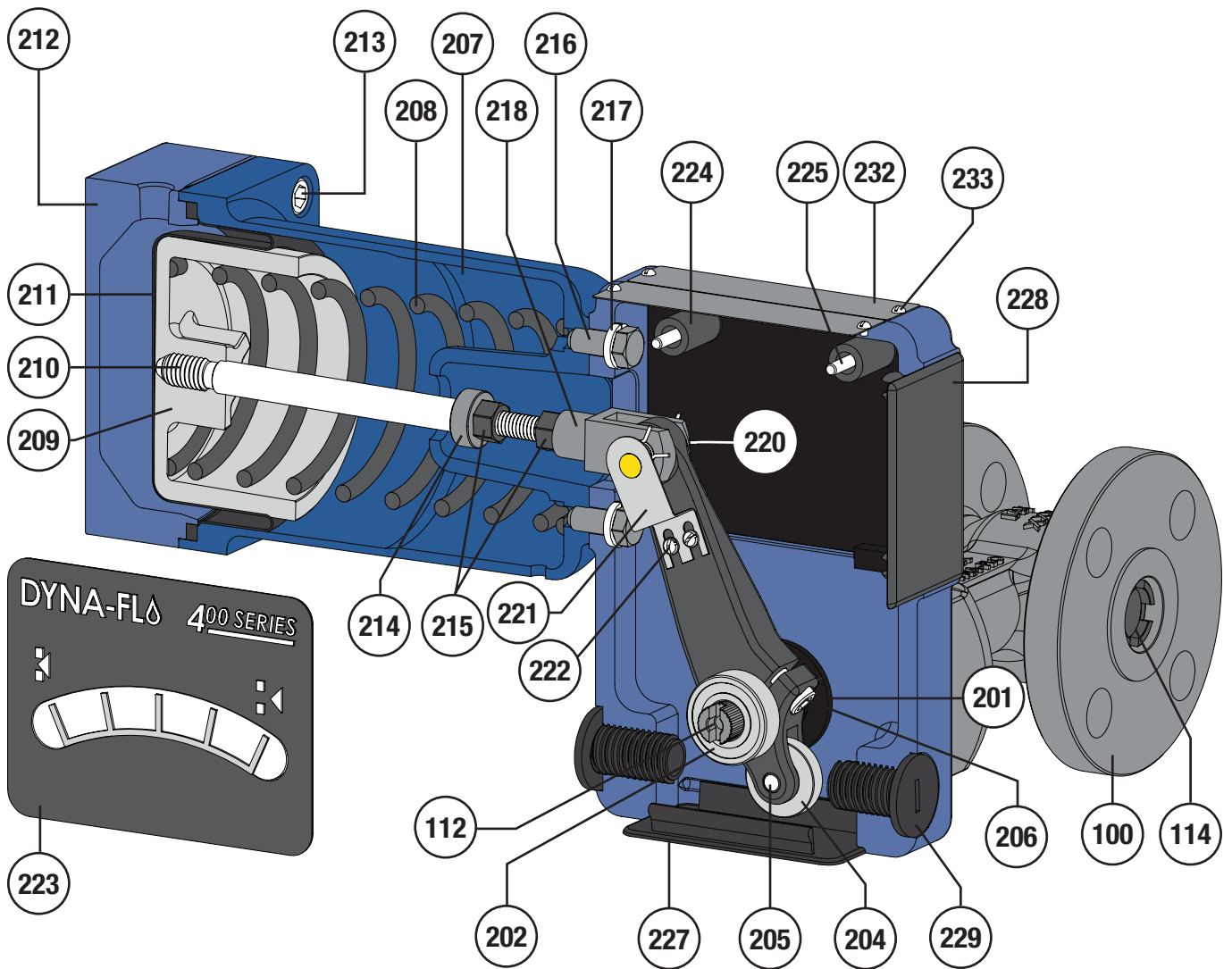
**Figure 61** Alternate Travel Stop Assembly



**Figure 62** Soft Seat Detail



**Figure 63** DF400 Valve Cross Section



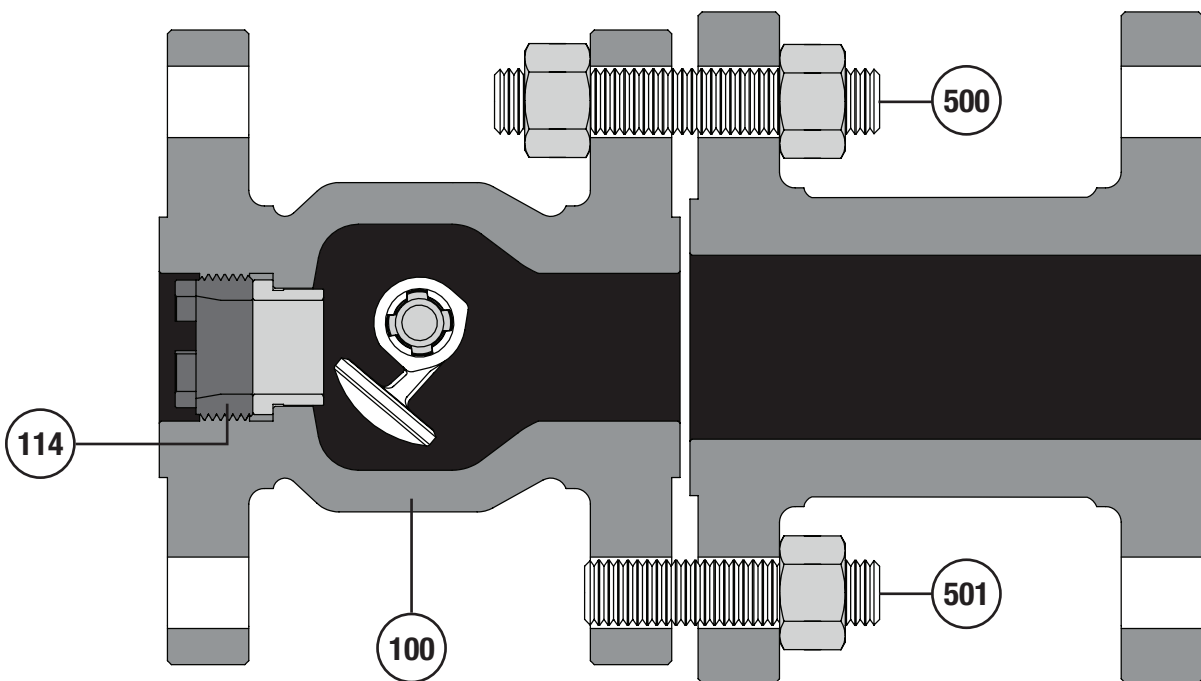
**Figure 64** DF400 Actuator Cross Section

**DF400 Flanged Valve Body Line Flange Stud Dimensions**

Valve Size	ASME Rating	Long Studs (Key 500)			Short Studs (Key 501)			Nuts Quantity
		Length Inch (mm)	Diameter	Quantity	Length Inch (mm)	Diameter	Quantity	
1" NPS (25mm DN)	Class 150	2.50 (63.5)	1/2" (M14)	8	-	-	-	16
	Class 300	3.00 (76.2)	5/8" (M16)	8	-	-	-	16
	Class 600	-	-	-	3.00 (76.2)	5/8" (M16)	8	8
2" NPS (50mm DN)	Class 150	3.25 (82.5)	5/8" (M16)	8	-	-	-	16
	Class 300	3.50 (88.9)	5/8" (M16)	16	-	-	-	32
	Class 600	4.25 (108)	5/8" (M16)	8	3.75 (95.2)	5/8" (M16)	8	24
3" NPS (80mm DN)	Class 150	3.50 (88.9)	5/8" (M16)	8	-	-	-	16
	Class 300	4.25 (108)	3/4" (M20)	16	-	-	-	32
	Class 600	5.00 (127)	3/4" (M20)	12	4.25 (108)	3/4" (M20)	4	28
4" NPS (100mm DN)	Class 150	3.50 (88.9)	5/8" (M16)	16	-	-	-	32
	Class 300	4.50 (114.3)	3/4" (M20)	16	-	-	-	32
	Class 600	5.75 (146)	7/8" (M24)	12	5.00 (127)	7/8" (M20)	4	28
6" NPS (150mm DN)	Class 150	4.00 (101.6)	3/4" (M20)	16	-	-	-	32
	Class 300	4.75" (120.6)	3/4" (M20)	24	-	-	-	48
	Class 600	6.75 (171.5)	1" (M27)	20	6.00 (152.4)	1" (M27)	4	44

1/2" : 1/2" 13 UNC 2A/2B
5/8" : 5/8" 11 UNC 2A/2B
3/4" : 3/4" 10 UNC 2A/2B

7/8" : 7/8" 9 UNC 2A/2B
1" : 1" 8 UNC 2A/2B
1-1/8" : 1-1/8" 8 UNC 2A/2B

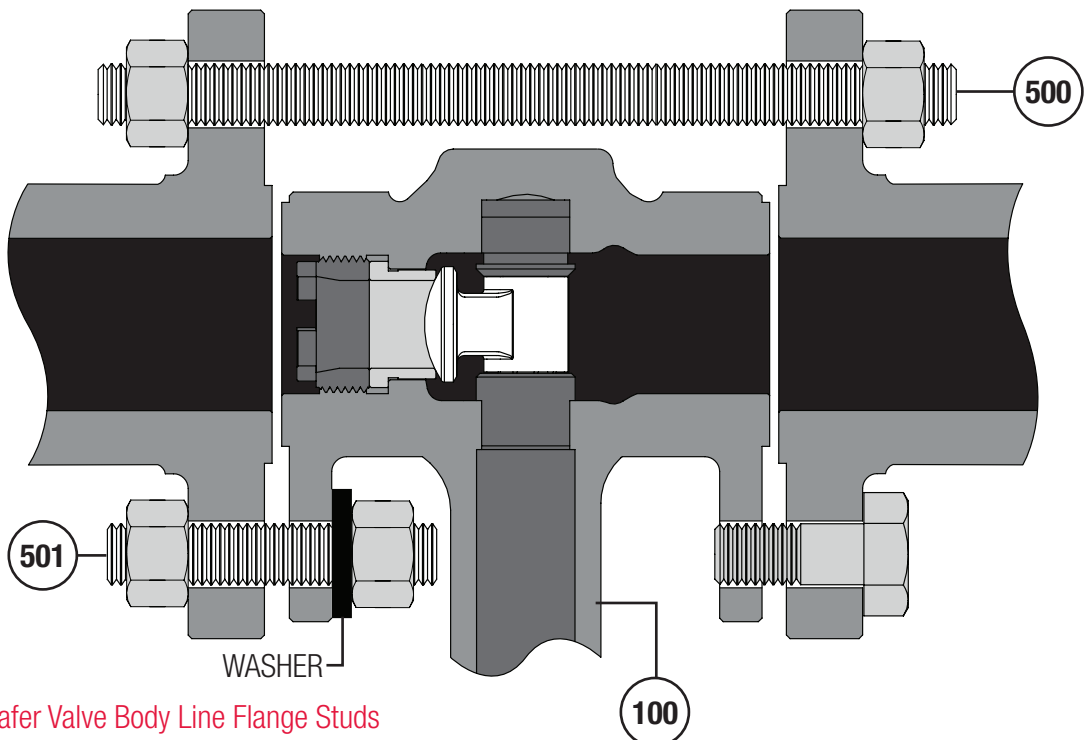


**Figure 65** Flanged Valve Body Line Flange Studs

**DF400 Wafer Valve Body Line Flange Stud Dimensions**

Valve Size	ASME Rating	Long Studs (Key 500)			Short Studs (Key 501) <sup>(1)</sup>			Nuts Quantity
		Length Inch (mm)	Diameter	Quantity	Length Inch (mm)	Diameter	Quantity	
1" NPS (25mm DN)	Class 150	7.50 (190)	1/2"	4	-	-	-	8
	Class 300	7.75 (195)	5/8"	4	-	-	-	8
	Class 600	7.75 (195)	5/8"	4	-	-	-	8
2" NPS (50mm DN)	Class 150	9.00 (230)	5/8"	4	-	-	-	8
	Class 300	9.00 (230)	5/8"	7	3.75 (95)	5/8"	2	18
	Class 600	9.00 (230)	5/8"	7	3.75 (95)	5/8"	2	18
3" NPS (80mm DN)	Class 150	10.25 (260)	5/8"	4	-	-	-	8
	Class 300	12.00 (305)	3/4"	7	4.50 (115)	3/4"	2	18
	Class 600	12.00 (305)	3/4"	7	4.50 (115)	3/4"	2	18
4" NPS (100mm DN)	Class 150	11.50 (290)	5/8"	7	3.75 (95)	5/8"	2	8
	Class 300	12.00 (305)	3/4"	7	4.50 (115)	3/4"	2	8
	Class 600	14.25 (360)	7/8"	7	5.50 (140)	7/8"	2	8
6" NPS (150mm DN)	Class 150	13.75 (350)	3/4"	7	4.50 (115)	3/4"	2	18(B)
	Class 300	13.75 (350)	3/4"	11	4.50 (115)	3/4"	2	26(B)
	Class 600	16.00 (400)	1"	11	6.00 (150)	1"	2	26(C)

<b>NOTES:</b> (1) Short studs (Key 501) require 1 washer each, as shown.	1/2" : 1/2" 13 UNC 2A/2B	7/8" : 7/8" 9 UNC 2A/2B
	5/8" : 5/8" 11 UNC 2A/2B	1" : 1" 8 UNC 2A/2B
	3/4" : 3/4" 10 UNC 2A/2B	1-1/8" : 1-1/8" 8 UNC 2A/2B



**Figure 66** Wafer Valve Body Line Flange Studs

**DF400 Valve Parts**

Key	Description	Part Number
<b>100</b>	<b>Body</b> If you need a body as a replacement part, order by valve size, serial number and desired material.	
<b>101</b>	<b>Stud, Mounting Body/Actuator</b> - ASTM A193 B8 (2 Required)	Contact Dyna-Flo
<b>102</b>	<b>Stud, Packing</b> - ASTM A193 B8 (2 Required)	Contact Dyna-Flo
<b>103</b>	<b>Lower Guide Bushing</b>	Refer to Table 10
<b>104</b>	<b>Lower Seal Bushing</b>	Refer to Table 11
<b>105</b>	<b>Inner O-Ring, Lower Seal Bushing</b>	Refer to Table 11
<b>106</b>	<b>Outer O-Ring, Lower/Upper Seal Bushing (2 Required)</b>	Refer to Table 11
<b>107</b>	<b>Plug</b>	Refer to Table 12
<b>108</b>	<b>Upper Guide Bushing</b>	Refer to Table 10
<b>109</b>	<b>Upper Seal Bushing</b>	Refer to Table 11
<b>110</b>	<b>Inner O-Ring, Upper Seal Bushing</b>	Refer to Table 11
<b>111</b>	<b>Spacer Tube, S31600</b> 1" NPS (25mm DN) Valve 2" NPS (50mm DN) Valve 3" NPS (80mm DN) Valve 4" NPS (100mm DN) Valve 6" NPS (150mm DN) Valve	035000-230-153D 435001-230-153D 435003-230-153D 435004-230-153D 400132-882-162D
<b>112</b>	<b>Shaft, S20910</b> 1" NPS (25mm DN) Valve 2" NPS (50mm DN) Valve 3" NPS (80mm DN) Valve 4" NPS (100mm DN) Valve 6" NPS (150mm DN) Valve	400130-828-215D 400130-830-215D 400130-831-215D 400130-832-215D 400130-833-215D
<b>113</b>	<b>Seat Ring</b>	Refer to Table 13
<b>114</b>	<b>Seat Ring Retainer</b>	Refer to Table 14
<b>115</b>	<b>Packing Box Ring, S31600</b> 1" NPS (25mm DN) Valve 2" NPS (50mm DN) Valve 3" NPS (80mm DN) Valve 4" NPS (100mm DN) Valve 6" NPS (150mm DN) Valve	435001-250-163D 435001-250-163D 435003-250-163D 435004-250-163D 435006-250-163D
<b>116</b>	<b>Safety Pin, S31600</b> 1" NPS (25mm DN) Valve 2" NPS (50mm DN) Valve 3" NPS (80mm DN) Valve 4" NPS (100mm DN) Valve 6" NPS (150mm DN) Valve	435000-270-163D 435000-270-163D 435003-270-163D 435004-270-163D 435003-270-163D

<b>117</b>	<b>Packing Set, Carbon Core Braided PTFE</b> 1" NPS (25mm DN) Valve 2" NPS (50mm DN) Valve 3" NPS (80mm DN) Valve 4" NPS (100mm DN) Valve 6" NPS (150mm DN) Valve	011488-500-999D 011488-500-999D 011488-501-999D 011488-502-999D 011488-503-999D
<b>118</b>	<b>Packing Follower, S31600</b> 1" NPS (25mm DN) Valve 2" NPS (50mm DN) Valve 3" NPS (80mm DN) Valve 4" NPS (100mm DN) Valve 6" NPS (150mm DN) Valve	011471-604-152D 011471-604-152D 011471-606-152D 011471-607-152D 011471-605-152D
<b>119</b>	<b>Inner O-Ring, Packing Follower</b> - VITON 1" NPS (25mm DN) Valve 2" NPS (50mm DN) Valve 3" NPS (80mm DN) Valve 4" NPS (100mm DN) Valve 6" NPS (150mm DN) Valve - KALREZ 1" NPS (25mm DN) Valve 2" NPS (50mm DN) Valve 3" NPS (80mm DN) Valve 4" NPS (100mm DN) Valve 6" NPS (150mm DN) Valve	400100-571-697D 400100-571-697D 971886-010-697D 971886-011-697D 971886-018-697D 400100-571-KALD 400100-571-KALD 971886-010-KALD 971886-011-KALD 971886-018-KALD
<b>120</b>	<b>Outer O-Ring, Packing Follower</b> - VITON 1" NPS (25mm DN) Valve 2" NPS (50mm DN) Valve 3" NPS (80mm DN) Valve 4" NPS (100mm DN) Valve 6" NPS (150mm DN) Valve - KALREZ 1" NPS (25mm DN) Valve 2" NPS (50mm DN) Valve 3" NPS (80mm DN) Valve 4" NPS (100mm DN) Valve 6" NPS (150mm DN) Valve	971886-121-697D 971886-121-697D 971886-006-697D 971886-018-697D 971886-023-697D 971886-121-KALD 971886-121-KALD 971886-006-KALD 971886-018-KALD 971886-023-KALD
<b>121</b>	<b>Packing Flange, Zinc Plated Steel</b> 1" NPS (25mm DN) Valve 2" NPS (50mm DN) Valve 3" NPS (80mm DN) Valve 4" NPS (100mm DN) Valve 6" NPS (150mm DN) Valve	435000-284-030D 435000-284-030D 435003-284-030D 435003-284-030D 435006-284-030D
<b>122</b>	<b>Nut, Packing</b> - ASTM A194 Grade 8 (2 Required)	Contact Dyna-Flo

## DF400 Valve Parts (Continued)

Key	Description	Part Number
<b>123</b>	<b>Nut</b> , Mounting Body/Actuator - ASTM A194 Grade 8 (2 Required)	Contact Dyna-Flo
<b>124</b>	<b>Flow Arrow</b> , S30400	Contact Dyna-Flo
<b>125</b>	<b>Machine Screw</b> , Flow Arrow, S31600 (2 Required)	Contact Dyna-Flo

## DF400 Actuator Parts

Key	Description	Part Number
<b>200</b>	<b>Yoke</b> , Cast Iron 4-1/2" (114mm) Actuator 6" (152mm) Actuator 7" (177mm) Actuator	035000-254-300D 035003-254-300D 035006-254-300D
<b>201</b>	<b>Grommet</b> , Neoprene 4-1/2" (114mm) Actuator 6" (152mm) Actuator/3" NPS (80mm DN) Valve 6" (152mm) Actuator/4" NPS (100mm DN) Valve 7" (177mm) Actuator	035000-330-779D 035003-330-779D 035004-330-779D 035006-330-779D
<b>202</b>	<b>Shaft Bearing</b> , Steel 4-1/2" (114mm) Actuator 6" (152mm) Actuator 7" (177mm) Actuator	971701-030-888D 435000-421-888D 435000-422-888D
<b>203</b>	<b>Lever</b> , Steel, Part Number is for Assembly, Includes Keys 204, 205, 206 4-1/2" (114mm) Actuator 6" (152mm) Actuator/3" NPS (80mm DN) Valve 6" (152mm) Actuator/4" NPS (100mm DN) Valve 7" (177mm) Actuator	035000-275-999D 035003-275-999D 035004-275-999D 035006-275-999D
<b>204</b>	<b>Lever Wheel</b> , S44004	
<b>205</b>	<b>Lever Dowel Pin</b> , Hardened Steel	
<b>206</b>	<b>Lever Socket Head Cap Screw</b> , Stainless Steel	
<b>207</b>	<b>Spring Barrel</b> , Die Cast Aluminum 4-1/2" (114mm) Actuator 6" (152mm) Actuator 7" (177mm) Actuator	035104-004-609D 035106-004-609D 035107-004-609D
<b>208</b>	<b>Spring</b> , Carbon Alloy 4-1/2" (114mm) Actuator 6" (152mm) Actuator 7" (177mm) Actuator	000043-107-009D 000044-065-130D 000044-065-130D
<b>209</b>	<b>Piston</b> , Die Cast Aluminum, Part Number is for Assembly & includes Key 210 4-1/2" (114mm) Actuator 6" (152mm) Actuator 7" (177mm) Actuator	035104-020-779D 035106-020-779D 035107-020-779D
<b>210</b>	<b>Piston Stem</b> , S30300	
<b>211</b>	<b>Diaphragm</b> , Nitrile/Polyester 4-1/2" (114mm) Actuator 6" (152mm) Actuator 7" (177mm) Actuator	035104-040-716D 035106-040-716D 035107-040-716D

<b>212</b>	<b>Diaphragm Case</b> , Die Cast Aluminum 4-1/2" (114mm) Actuator 6" (152mm) Actuator 7" (177mm) Actuator	035104-014-609D 035106-014-609D 035107-014-609D
<b>213</b>	<b>Cap Screw</b> , Diaphragm Case, Steel	Contact Dyna-Flo
<b>214</b>	<b>Stem Travel Stop</b> , S30400 4-1/2" (114mm) Actuator 6" (152mm) Actuator 7" (177mm) Actuator	035000-350-153D 035003-350-153D 035006-350-153D
<b>215</b>	<b>Locknut</b> , Travel Stop/Clevis, Steel (2 Required) 4-1/2" (114mm) Actuator 6" (152mm) Actuator 7" (177mm) Actuator	971511-012-158D 971511-014-158D 971511-016-158D
<b>216</b>	<b>Cap Screw</b> , Spring Barrel Mounting, Steel 4-1/2" (114mm) Actuator (2 Required) 6" (152mm) Actuator (4 Required) 7" (177mm) Actuator (4 Required)	971004-013-110 H5CZ38.114 971012-021-110
<b>217</b>	<b>Lock Washer</b> , Spring Barrel Mounting, Steel 4-1/2" (114mm) Actuator (2 Required) 6" (152mm) Actuator (4 Required) 7" (177mm) Actuator (4 Required)	LWZ38 LWZ38 LWZ38
<b>218</b>	<b>Clevis</b> , Zinc Plated Steel 4-1/2" (114mm) Actuator 6" (152mm) Actuator 7" (177mm) Actuator	435103-100-250D 435105-100-250D 435106-100-250D
<b>219</b>	<b>Clevis Pin</b> , S30400 4-1/2" (114mm) Actuator 6" (152mm) Actuator 7" (177mm) Actuator	435000-340-215D 435003-340-215D 435006-340-215D
<b>220</b>	<b>Clevis Pin Clip</b> , S30200 (2 Required) 4-1/2" (114mm) Actuator 6" (152mm) Actuator 7" (177mm) Actuator	435000-521-151D 435000-522-151D 435000-522-151D
<b>221</b>	<b>Travel Indicator</b> , S30200 4-1/2" (114mm) Actuator 6" (152mm) Actuator 7" (177mm) Actuator	035000-420-151D 035006-420-151D 035007-420-151D
<b>222</b>	<b>Machine Screws</b> , Travel Indicator, S31600 4-1/2" (114mm) Actuator 6" (152mm) Actuator 7" (177mm) Actuator	MPPS632X014 MPPS632X014 MPPS632X014
<b>223</b>	<b>Front Cover</b> , Polycarbonate 4-1/2" (114mm) Actuator 6" (152mm) Actuator 7" (177mm) Actuator	035000-282-707D 035003-282-707D 035006-282-707D

**DF400 Actuator Parts (Continued)**

Key	Description	Part Number
<b>224</b>	<b>Rear Cover</b> , Polycarbonate	
	4-1/2" (114mm) Actuator	035000-283-707D
	6" (152mm) Actuator	035003-283-707D
	7" (177mm) Actuator	035006-283-707D
<b>225</b>	<b>Cover Screws</b> , Zinc Plated Steel (2 Required)	
	4-1/2" (114mm) Actuator	971266-017-110D
	6" (152mm) Actuator	971266-020-110D
	7" (177mm) Actuator	971266-022-110D
<b>226</b>	<b>Cover Screw Retainer (O-Ring)</b> , Nitrile (2 Required)	
	4-1/2" (114mm) Actuator	971886-039-680D
	6" (152mm) Actuator	971886-039-680D
	7" (177mm) Actuator	971886-039-680D
<b>227</b>	<b>Bottom Cover</b> , Polycarbonate	
	4-1/2" (114mm) Actuator	035000-284-707D
	6" (152mm) Actuator	035003-284-707D
	7" (177mm) Actuator	035006-284-707D
<b>228</b>	<b>Side Cover</b> , Polycarbonate	
	4-1/2" (114mm) Actuator	035000-285-707D
	6" (152mm) Actuator	035003-286-707D
	7" (177mm) Actuator	035006-286-707D
<b>229</b>	<b>Thread Plug</b> , Polycarbonate (2 Required)	
	4-1/2" (114mm) Actuator	035000-287-707D
	6" (152mm) Actuator	035000-287-707D
	7" (177mm) Actuator	035000-287-707D
<b>230</b>	<b>Shaft Cover</b> , Polycarbonate	
	4-1/2" (114mm) Actuator	035000-286-707D
	6" (152mm) Actuator	035000-286-707D
	7" (177mm) Actuator	035000-286-707D
<b>231</b>	<b>Machine Screw</b> , Shaft Cover, S31600	
	4-1/2" (114mm) Actuator	971246-015-250D
	6" (152mm) Actuator	971246-015-250D
	7" (177mm) Actuator	971246-015-250D
<b>232</b>	<b>Nameplate</b> , S30400	NAMEXPED034A
<b>233</b>	<b>Machine Screws</b> , Nameplate, Steel (4 Required)	971335-002-250D

**DF400 Handwheel Parts**

Key	Description	Part Number
<b>300</b>	<b>Handwheel</b> , Aluminum	
<b>301</b>	<b>Handwheel Screw</b> , S41600	
<b>302</b>	<b>Handwheel Lock</b> , Die Cast Aluminum	
<b>303</b>	<b>Handwheel Washer</b> , Steel	
<b>304</b>	<b>Handwheel E-Clip</b> , Steel	
<b>305</b>	<b>Handwheel Direction Plate</b> , Polycarbonate	
<b>306</b>	<b>Handwheel Plate Screws</b> , S31600	
<b>Handwheel Assembly Part Number</b>		
	4-1/2" (114mm) Actuator	011471-141-999D
	6" (152mm) Actuator	400135-927-999D
	7" (177mm) Actuator	011471-142-999D

**DF400 Travel Stop Parts**

Key	Description	Part Number
<b>400</b>	<b>Travel Stop</b> , Steel	
<b>401</b>	<b>Travel Stop Locknut</b> , Steel	
<b>Travel Stop Assembly Part Number</b>		
	4-1/2" (114mm) Actuator	400135-927-999D
	6" (152mm) Actuator	403102-98-999D
	7" (177mm) Actuator	

Table 10

### Lower Guide Bushing (Key 103) / Upper Guide Bushing (Key 108)

Valve Size	Material	Part Number	
		Key 103	Key 108
1" NPS (25mm DN)	S44004 (Standard)	435000-160-220D	435000-140-220D
	R30006 (NACE)	435000-160-567D	435000-140-567D
2" NPS (50mm DN)	S44004 (Standard)	435001-160-220D	435001-140-220D
	R30006 (NACE)	435001-160-567D	435001-140-567D
3" NPS (80mm DN)	S44004 (Standard)	035003-164-220D	435003-140-220D
	R30006 (NACE)	035003-164-567D	435003-140-567D
4" NPS (100mm DN)	S44004 (Standard)	035004-164-220D	435004-140-220D
	R30006 (NACE)	035004-164-567D	435004-140-567D
6" NPS (150mm DN)	S44004 (Standard)	035006-164-220D	435006-140-220D
	R30006 (NACE)	035006-164-567D	435006-140-567D

Table 11

### Lower Seal Bushing (Key 104) & Upper Seal Bushing (Key 109) / O-Rings (Keys 105, 106, 110)

Materials	Valve Size	Seal Bushing Part Number		O-Ring Part Numbers		
		Key 104	Key 109	Key 105	Key 106	Key 110
S44004 Bushings / VTION O-Rings (Standard)	1" NPS (25mm DN)	400137-791-220D	400139-250-220D	971886-021-697D	971886-136-697D	971886-102-697D
	2" NPS (50mm DN)	435001-172-220D	435001-152-220D	971886-102-697D	971886-136-697D	971886-088-697D
	3" NPS (80mm DN)	035003-165-220D	435003-152-220D	971886-184-697D	971886-145-697D	971886-101-697D
	4" NPS (100mm DN)	035004-165-220D	435004-152-220D	971886-185-697D	971886-117-697D	971886-098-697D
	6" NPS (150mm DN)	035006-165-220D	435006-152-220D	971886-186-697D	971886-147-697D	971886-146-697D
R30006 Bushings / KALREZ O-Rings (NACE)	1" NPS (25mm DN)	400137-791-567D	400139-250-567D	971886-021-KALD	971886-136-KALD	971886-102-KALD
	2" NPS (50mm DN)	435001-172-567D	435001-152-567D	971886-102-KALD	971886-136-KALD	971886-088-KALD
	3" NPS (80mm DN)	035003-165-567D	435003-152-567D	971886-184-KALD	971886-145-KALD	971886-101-KALD
	4" NPS (100mm DN)	035004-165-567D	435004-152-567D	971886-185-KALD	971886-117-KALD	971886-098-KALD
	6" NPS (150mm DN)	035006-165-567D	435006-152-567D	971886-186-KALD	971886-147-KALD	971886-146-KALD

Table 12

### Plug (Key 107)

Valve Size	Part Number	
	R30006	S31603/CoCr-A Hard Faced Seat
1" NPS (25mm DN)	435000-104-567D	N/A
2" NPS (50mm DN)	435002-104-567D	N/A
3" NPS (80mm DN)	035003-104-567D	035003-104-594D
4" NPS (100mm DN)	035004-104-567D	035004-104-594D
6" NPS (150mm DN)	N/A	035006-104-594D

**Table 13**

**Seat Ring (Key 113)**

Valve Size	Factor	Part Number			
		R30006	S31600/S31603	S31600/CoCr-A Hard Faced Seat & Bore	S31600/PTFE
1" NPS (25mm DN)	0.2	011471-324-567D	011471-324-163D	N/A	N/A
	0.4	035000-185-567D	035000-185-163D	N/A	035000-189-999D
	0.6	011471-204-567D	011471-204-163D	N/A	011471-219-999D
	1	035000-184-567D	035000-184-163D	N/A	035000-187-999D
2" NPS (50mm DN)	0.2	011471-358-567D	011471-358-163D	N/A	N/A
	0.4	435002-181-567D	435002-181-163D	N/A	435002-191-999D
	0.6	011471-205-567D	011471-205-163D	N/A	011471-209-999D
	1	435002-180-567D	435002-180-163D	N/A	435002-190-999D
3" NPS (80mm DN)	0.4	435003-182-567D	435003-182-163D	400097-071-596D	435003-192-999D
	0.6	011471-201-567D	011471-201-163D	400089-729-596D	011471-211-999D
	1	435003-180-567D	435003-180-163D	400085-265-596D	435003-193-999D
4" NPS (100mm DN)	0.4	435004-184-567D	435004-184-163D	400085-534-596D	435004-194-999D
	0.6	011471-206-567D	011471-206-163D	400106-731-596D	011471-213-999D
	1	435004-181-567D	435004-181-163D	400085-266-596D	435004-195-999D
6" NPS (150mm DN)	0.4	011471-119-596D	435006-184-163D	435006-184-567D	435006-194-999D
	0.6	011471-299-596D	011471-207-163D	011471-207-567D	011471-215-999D
	1	400085-267-596D	435006-181-163D	435006-181-567D	435006-195-999D

**Table 14**

**Seat Ring Retainer (Key 114)**

Valve Size	Part Number	
	R30006	S31600/S31603 Dual Grade
1" NPS (25mm DN)	035000-244-567D	035000-244-163D
2" NPS (50mm DN)	435002-244-567D	435002-244-163D
3" NPS (80mm DN)	435003-244-567D	435003-244-163D
4" NPS (100mm DN)	435004-244-567D	435004-244-163D
6" NPS (150mm DN)	435006-244-567D	435006-244-163D

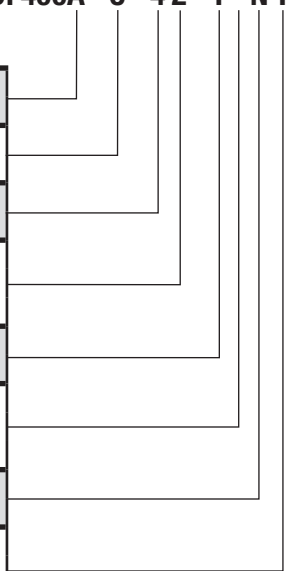
This page intentionally left blank.

This page intentionally left blank.

# DF400 ACTUATOR NUMBERING SYSTEM

SAMPLE PART NUMBER: **DF400A - C - 4 2 - 1 - N 1**

ACTUATOR CERTIFICATION						A		
<b>A</b>	STANDARD	<b>AE</b>	PED 2014/68/EU			<b>A</b>		
FAIL POSITION						C		
<b>C</b>	CLOSE (AIR TO OPEN)	<b>O</b>	OPEN (AIR TO CLOSE)			<b>C</b>		
ACTUATOR SIZE						4		
<b>4</b>	4-1/2" (114MM)	<b>6</b>	6" (152MM)	<b>7</b>	7" (178MM)	<b>4</b>		
VALVE SIZE NPS(DN)						2		
<b>1</b>	1 INCH (25MM)	<b>5</b>	1-1/2 INCH (40MM)	<b>2</b>	2 INCH (50MM)	<b>2</b>		
<b>4</b>	4 INCH (100MM)	<b>6</b>	6 INCH (150MM)			<b>2</b>		
SPRING RANGE						1		
<b>1</b>	7-15 PSIG (0.48-1.03 BARG)			<b>2</b>	7-24 PSIG (0.48-1.65 BARG)		<b>1</b>	
PAINT						-		
-	DFPS-01 (STANDARD)			<b>2</b>	DFPS-02 (SEVERE SERVICE)		<b>-</b>	
<b>3</b>	DFPS-03 (HIGH TEMPERATURE)					<b>-</b>		
HANDWHEEL						N		
<b>N</b>	NONE	<b>H</b>	HANDWHEEL			<b>N</b>		
MOUNTING POSITION (REFER TO PAGE 6)						1		
<b>1</b>	POSITION 1	<b>2</b>	POSITION 2	<b>3</b>	POSITION 3	<b>4</b>	POSITION 4	<b>1</b>
<b>5</b>	POSITION 5	<b>6</b>	POSITION 6	<b>7</b>	POSITION 7	<b>8</b>	POSITION 8	<b>1</b>



**DF400** - - - - -

## DF400 VALVE NUMBERING SYSTEM

SAMPLE PART NUMBER: DF400V - 1 A FL - N A C - V F 1

VALVE CERTIFICATION						V		
V	STANDARD				VE	PED 2014/68/EU	V	
VALVE SIZE NPS(DN)						1		
1	1 INCH (25MM)	5	1-1/2 INCH (40MM)	2	2 INCH (50MM)	3	3 INCH (80MM)	1
4	4 INCH (100MM)	6	6 INCH (150MM)					
ASME RATING						A		
A	150	B	300	C	600	D	150-600 (WAFER)	A
END CONNECTION						F		
F	RF	W	WAFER					F
BODY MATERIAL						L		
W	WCC	M	CF3M					L
PACKING TYPE						-		
-	BRAIDED CARBON PTFE						-	
SHAFT STYLE						N		
N	SPLINED (STANDARD)	P	SQUARE	K	KEYED			N
TRIM						A		
A	TRIM STYLE A			B	TRIM STYLE B		A	
C	TRIM STYLE C			D	TRIM STYLE D			
E	TRIM STYLE E			F	TRIM STYLE F			
G	TRIM STYLE G			H	TRIM STYLE H			
BUSHINGS						C		
A	R30006	C	S44004	R	R30006 WITH O-RINGS	S	S44004 WITH O-RINGS	C
PAINT						-		
-	DFPS-01 (STANDARD)			2	DFPS-02 (SEVERE SERVICE)		-	
3	DFPS-03 (HIGH TEMPERATURE)							
O-RING MATERIAL						V		
-	VITON	K	KALREZ®					V
FLOW DIRECTION						F		
F	FLOW TO OPEN	R	FLOW TO CLOSE					F
CV FACTOR						1		
4	0.20	3	0.40	2	0.60	1	1.00	1

DF400 - - - - -

**NOTE:** DF400 Actuator Model Builder is located on Page 43.

### Curtiss-Wright Flow Control Company Canada, doing business as Dyna-Flo Control Valve Services

**Headquarters:** 4810 92 Avenue, Edmonton, AB, T6B 2X4 Canada • Telephone: 1-866-396-2356 • [valves.curtisswright.com](http://valves.curtisswright.com)

**Offices Worldwide:** For a listing of our global sales network, visit [valves.curtisswright.com/en-us/global-supplier-network](http://valves.curtisswright.com/en-us/global-supplier-network)

While this information is presented in good faith and believed to be accurate, Curtiss-Wright Flow Control Company Canada, doing business as Dyna-Flo Control Valve Services, does not guarantee satisfactory results from reliance on such information. Nothing contained herein is to be construed as a warranty or guarantee, expressed or implied, regarding the performance, merchantability, fitness or any other matter with respect to the products, nor as a recommendation to use any product or process in conflict with any patent. Curtiss-Wright Flow Control Company Canada, doing business as Dyna-Flo Control Valve Services, reserves the right, without notice, to alter or improve the designs or specifications of the products described herein.

© 2026 Curtiss-Wright. All rights reserved. Specifications are subject to change without notice. All trademarks are property of their respective owners.  
Catalog # Model 400 Series Control Valve Technical Sales Bulletin

