



6400/6600 SERIES

Safety Valves for ASME Section I and VIII Boiler Applications

Curtiss-Wright is a worldwide leader in delivering solutions to improve safety, plant flexibility, reliability, and efficiency. Farris Engineering, a division of Curtiss-Wright, has been at the forefront in the design and manufacture of spring-loaded and pilot-operated pressure relief valves since 1943.

Our Commitment: To provide customers with total pressure and flow control management solutions supporting a facility's entire life cycle, transforming and ensuring plant safety.

Focused On Customer Solutions

Experienced Engineers • Solution Management • Superior Products

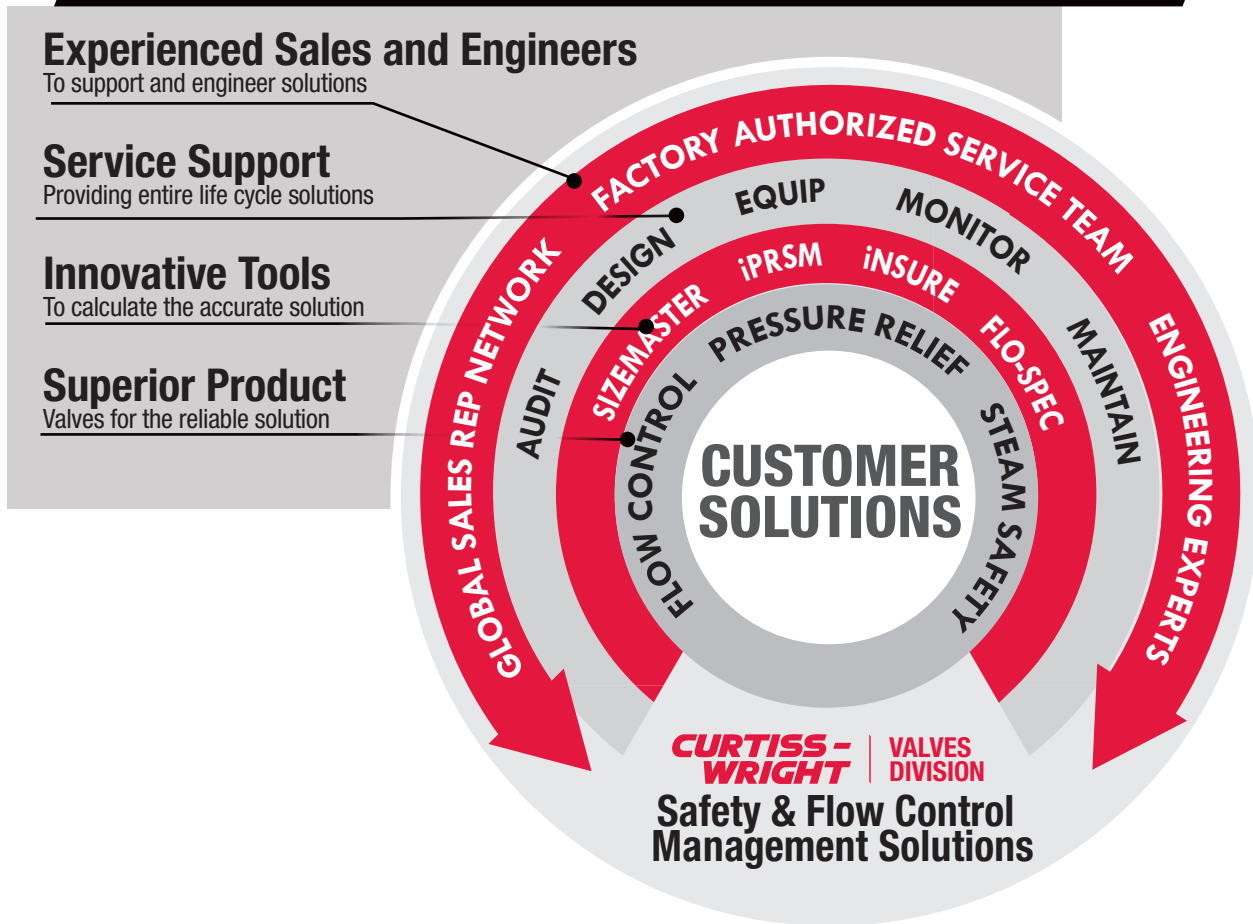

Factory Authorized Service Team

Sales Representative Network

- Factory trained technicians in OEM specifications
- Local service and in-line testing reducing maintenance cost.
- Capability to track and manage relief valve maintenance and repair history
- Access to sales network, and keeping global inventory local

<https://www.cw-valvegroup.com/en-gb/contact-us>



Solutions Management and Innovative Tools



SOFTWARE MANAGEMENT TOOL FOR PRESSURE RELIEF SYSTEMS

Software Capabilities

- Overpressure analysis with relief load calculations
- Inlet and outlet piping hydraulic calculations
- Header blowdown and knockout drum calculations
- Acoustic induced vibration analysis

VALVE SIZING AND SELECTION SOFTWARE



- Provides sizing for vapor, liquid, steam and two-phase flow
- Capable of multi-scenario sizing. Multi-valve algorithm to easily size from multiple valves

- Built-in catalog selector ensures the proper product appropriate based on pressure and temperature
- Compliant with ASME and API



- Capable of multi-scenario sizing. Multi-valve algorithm to easily size from multiple valves
- Develop, dimensional drawings

- Maintain project data
- Generate orders to be sent direct to production

Product Training and Seminars



We offer technical training courses learning about valve management and industry scenarios.

SOME AVAILABLE CLASSES

- Pressure relief valve functionality
- Sizing requirements
- Material selection
- Sizing software training
- Maintenance and repair
- Mitigating overpressure scenarios

Contact your sales rep for more information.

Table of Contents

Introduction & Warranty	3
Numbering System	4
Bill of Materials.....	5-6
Selection Tables	
6400 US Customary System Units	7-8
6400 Metric System Units	9-10
6600 US Customary System Units	11
6600 Metric System Units	12
Capacity Tables, US Customary System Units	
Steam 3% Overpressure	13
Steam 10% Overpressure.....	14
Capacity Table, Metric System Units	
Steam 3% Overpressure	15
Steam 10% Overpressure.....	16
Sizing Information.....	17
Dimensions & Weights.....	18
Conversion Factors.....	19

Introduction

Designed with the user in mind, Series 6400 and 6600 safety valves represent the most advanced technology in valves designed for use in intermediate power boiler and organic fluid vaporizer service. Built in conformance to Section I and Section VIII of the ASME Boiler and Pressure Vessel Code, all capacities are certified by The National Board of Boiler and Pressure Vessel Inspectors at 3% overpressure.

Features Include:

- Full nozzle design for minimized maintenance
- Hardened conical disc for extended seat life
- Monel® or copper nickel alloy guides with long guiding ratio for reduced galling used on high temperature models
- Set pressure to 1500 psig, temperatures to 1000 °F
- Available in closed bonnet or exposed spring versions
- Dual blow down ring for more precise performance

Warranty

All products manufactured by Farris Engineering are warranted free of defects in material and workmanship when used within the range recommended for a period of one year after installation or eighteen months from delivery. When authorized, any defective product may be returned to the factory and if found defective will be repaired or replaced free of charge, solely at the discretion of Farris Engineering, ex-works our factory. No charge for labor or other expense incurred will be allowed, as the liability of Farris Engineering is measured by the refund price of the defective product only. All warranties are based on the product being used within the range recommended and does not cover damages or defects due to normal wear and tear, misuse, alteration or neglect. The purchaser shall determine the suitability of the product for use and assumes all risks and liabilities in connection therewith.

This warranty does not cover the performance of valves tested at site on test equipment that is not to the same technical standard as that used by the manufacturer.

Type Numbering System

The type numbering system of the Farris 6400 and 6600 series valve is illustrated below. The type number which describes the metallurgy and construction can be found on the nameplate of every 6400 and 6600 series valve.

64/													
66	D	A			1	2		D	-1	7	0		
Series Number	Orifice	Seat Construction			Temperature & Material		Inlet Flange	Special Construction	Inlet Facing	Cap Construction	Option		
64 Open Bonnet	Orifice Letter	Actual Area Sq. In.	Actual Area mm ²	A Metal Seat	Designation	Inlet Temperature	Material		0 150	D Organic Fluid Vaporizer ⁴	1 Raised Face	2 Screwed Cap ⁵	0 No Gag
							Body & Bonnet	Spring					
66 Closed Bonnet	D	0.150	97		1	up to 800 °F (427 °C)	Carbon Steel	Chrome Alloy	2 300	9 Ring Joint	4 Packed Lever	1 With Gag	
	E	0.225	145										
	F	0.371	239		2 ¹	n/a	n/a	n/a	3 600	7 Open Lever ²			
	G	0.559	361		3 ²	801 to 1000 °F (427 to 538 °C)	Chrome Moly Steel ³	Chrome Alloy			4 900		
	H	0.873	563						5 1500				
	J	1.430	923										
	K	2.042	1317										
	L	3.170	2045										
	M	4.000	2581										
	N	4.822	3111										
P	7.087	4572											

Ordering Information

In order to assist you in the proper processing of your order, please specify the following information so that we may process your order as quickly and accurately as possible.

- Quantity
- Inlet and outlet sizes*
- Farris type number*
- Inlet and outlet flange class*
- Set pressure*
- Operating temperature*
- Relieving temperature*
- Allowable overpressure*
- Fluid and state*
- Required capacity*
- Materials of construction if other than standard
- Accessories, such as test gag
- Code requirements
- Any special testing or documentation requirements

*As a customer service, we verify your sizing and selection. To do this, we must have this information.

Notes:

- Obsolete designation. The temperature range for designation 2 is now covered under designation 1.
- Option only available on 6400 Series.
- The open bonnet 6400 series uses a carbon steel bonnet for all temperature ranges.
- D option available on 6600 Series only.
- Option only available on 6600 Series valve for organic fluid vaporizer service.

Parts Replacement

Valves – If an exact replacement valve is required, then the valve type, size and serial number must be specified to ensure proper dimensions and material being supplied. If a specific valve is obsolete, a recommendation of the current equivalent will be made if possible.

Spare Parts – When ordering parts, use part names as listed in the bills of materials. Specify valve type, size and serial number. If the serial number is not available, the original Farris factory order number will help us supply the proper part and material.

Springs – Order as an assembly to include spring with upper and lower spring buttons. Specify valve type, size, serial number, set pressure and backpressure, if any.

Note: If valve modification or set pressure changes are required, consideration must be given to correct the nameplate and other data.

Series 6400/6600

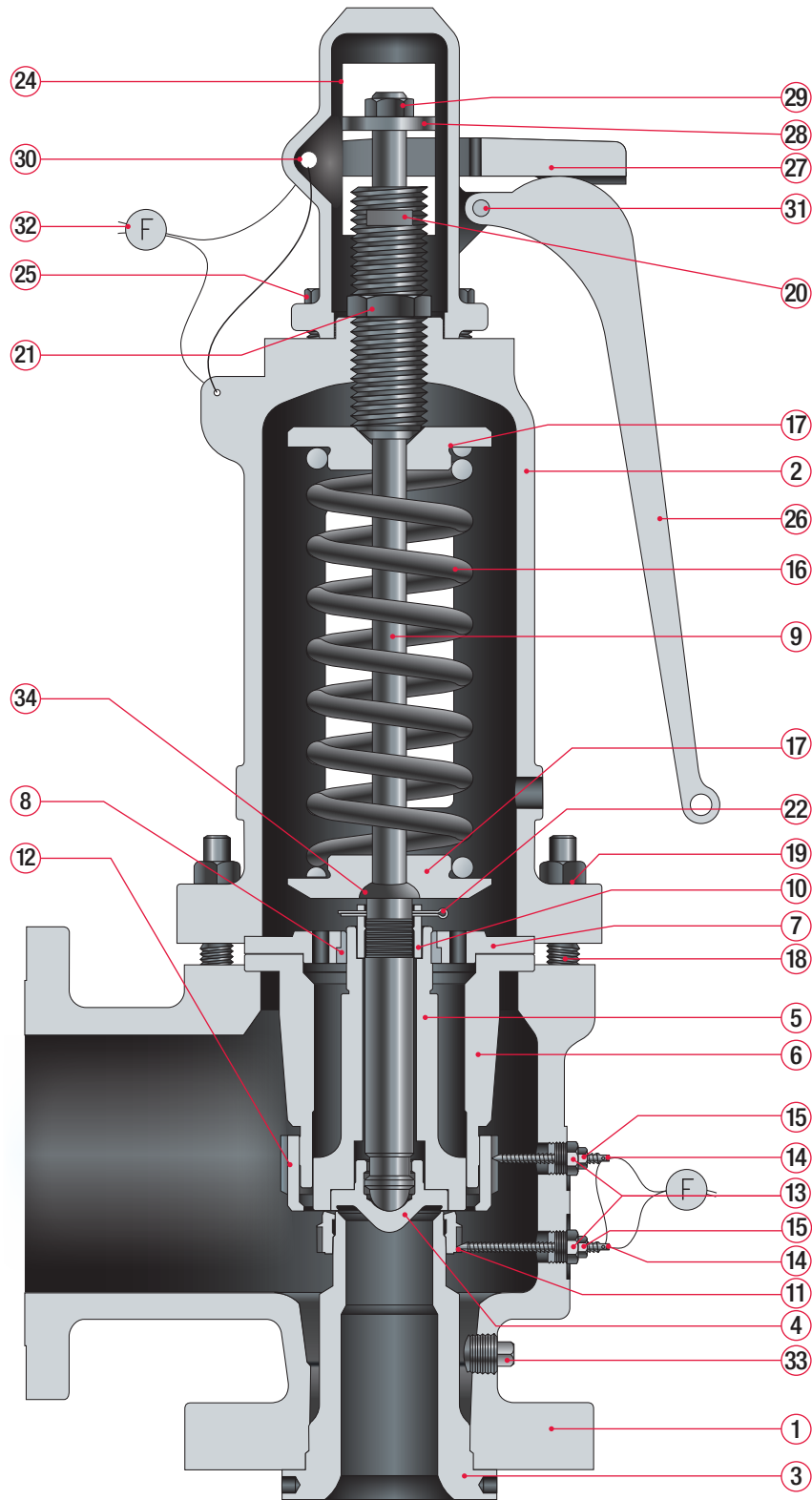

6400 Series, L & M Orifices

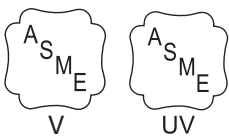

Built in conformance to ASME Code Sections I and VIII for Steam Service

Bill of Materials		
Item No.	Part Name	Material
1	Body (up to 800 °F) ³ Body (801 to 1000 °F)	SA-216 GR. WCB Carbon Steel SA-217 GR. WC6 Alloy Steel (1 1/4 CR-1/2 Moly)
2	Open Bonnet (6400 Series) Closed Bonnet (6600 Series) ³	SA-216 GR. WCB Carbon Steel SA-216 GR. WCB Carbon Steel
3	Nozzle	316 Stainless Steel
4	Disc	Precipitation Hardened St. St.
5	Disc Holder	Precipitation Hardened St. St.
6	Sleeve Guide (Up to 800 °F) ³ Sleeve Guide (801 to 1000 °F)	300 Series Stainless Steel Monel
7	Guide Plate ¹	300 Series Stainless Steel
8	Guide Bushing ¹	Monel
9	Stem	316 Stainless Steel
10	Stem Collar	316 Stainless Steel
11	Blow Down Ring-Lower	316 Stainless Steel
12	Blow Down Ring-Upper	316 Stainless Steel
13	Lock Screw (Blow Down Ring)	316 Stainless Steel
14	Lock Screw Stud (BDR)	316 Stainless Steel
15	Jam Nut, Lock Screw	Stainless Steel
16	Spring	Chrome Alloy, Rust Proofed
17	Spring Buttons	316 Stainless Steel
18	Body Stud	ASTM A193 Gr. B7 Alloy Steel
19	Hex Nut, Body	ASTM A194 GR. 2H Alloy Steel
20	Spring Adjusting Screw	Precipitation Hardened St. St.
21	Spring Adj. Scr. Jam Nut	316 Stainless Steel
22	Cotter Pin	Steel, Pltd.
23	Spring Pin (not shown)	Carbon Steel, Pltd.
24	Cap (6400 Series) Cap (6600 Series)	Iron Steel
25	Cap Screw	Carbon Steel, Pltd.
26	Test Lever	Iron
27	Test Lever Fork	Iron
28	Stem Test Nut	316 Stainless Steel
29	Jam Nut, Stem	Stainless Steel
30	Round Head Rivet (Fork)	Steel
31	Round Head Rivet (Lever)	Steel
32	Wire Seal	St. St. Wire / Lead Seal
33	Pipe Plug, Body	Steel
34	Stem Shoulder	Precipitation Hardened St. St.
35	Pipe Plug, Bonnet (Not Shown)	Steel
36	Nameplate (Not Shown)	Stainless Steel

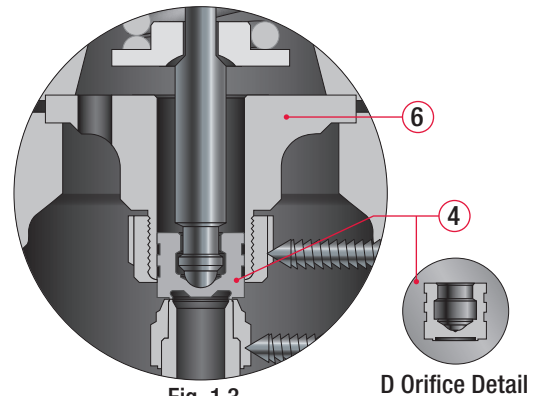

Fig. 1.3
Internals for Orifices D, E, & F

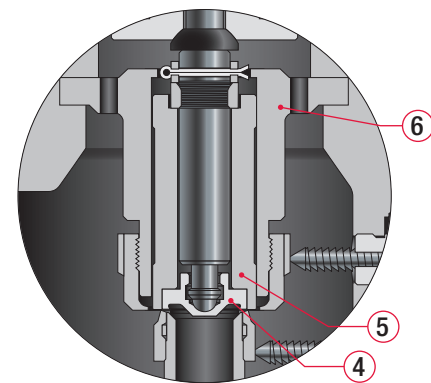

Fig. 1.4
Internals for Orifice G

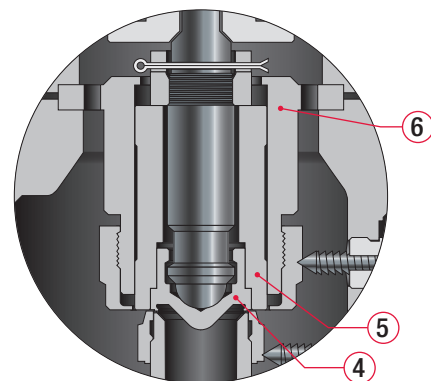

Fig. 1.5
Internals for Orifices H & J



General Notes:

1. Guide plate and guide bushing form a one piece assembly. Used on 2-1/2" to 4" inlet sizes only. No bushing is used on valves up to 800 °F.
2. Gaskets (not shown above) are used on Series 6600 closed bonnet units only. Material is stainless steel.
3. 6600 Series only available to 800 °F (427 °C)

Selection Table – Series 6400

US Customary System Units																
Orifice		Valve Size Inlet x Outlet	ANSI Flange Class		Type Number	Maximum Set Pressure, psig								Material		
Letter	Area sq. in.		Inlet RF	Outlet RF		300 °F	400 °F	500 °F	600 °F	700 °F	800 °F	900 °F	1000 °F	Body & Bonnet ⁷	Spring	
D	0.150	1 x 2	300#	150#	64DA12-170	300	300	300	300	300	300	–	–	Carbon Steel	Chrome Alloy, Rust Proofed	
			600#		64DA13-170	600	600	600	600	600	600	–	–			
			900#		64DA14-170	900	900	900	900	900	900	–	–			
			1500#		64DA15-170	1500	1500	1500	1500	1500	1500	–	–			
		1 x 2	300#	150#	64DA32-170	–	–	–	–	–	300	300	215	Chrome Moly Steel		
			600#		64DA33-170	–	–	–	–	–	600	600	430			
			900#		64DA34-170	–	–	–	–	–	900	900	650			
			1500#		64DA35-170	–	–	–	–	–	1500	1500	1080			
E	0.225	1 x 2	300#	150#	64EA12-170	300	300	300	300	300	300	–	–	Carbon Steel	Chrome Alloy, Rust Proofed	
			600#		64EA13-170	600	600	600	600	600	600	–	–			
			900#		64EA14-170	900	900	900	900	900	900	–	–			
			1500#		64EA15-170	1500	1500	1500	1500	1500	1500	–	–			
		1 x 2	300#	150#	64EA32-170	–	–	–	–	–	300	300	215	Chrome Moly Steel		
			600#		64EA33-170	–	–	–	–	–	600	600	430			
			900#		64EA34-170	–	–	–	–	–	900	900	650			
			1500#		64EA35-170	–	–	–	–	–	1500	1500	1080			
F	0.371	1 1/2 x 2	300#	150#	64FA12-170	300	300	300	300	300	300	–	–	Carbon Steel	Chrome Alloy, Rust Proofed	
			600#		64FA13-170	600	600	600	600	600	600	–	–			
			900#		64FA14-170	900	900	900	900	900	900	–	–			
			1500#		64FA15-170	1500	1500	1500	1500	1500	1500	–	–			
		1 1/2 x 2	300#	150#	64FA32-170	–	–	–	–	–	300	300	215	Chrome Moly Steel		
			600#		64FA33-170	–	–	–	–	–	600	600	430			
			900#		64FA34-170	–	–	–	–	–	900	900	650			
			1500#		64FA35-170	–	–	–	–	–	1500	1500	1080			
G	0.559	1 1/2 x 3	300#	150#	64GA12-170	300	300	300	300	300	300	–	–	Carbon Steel	Chrome Alloy, Rust Proofed	
			600#		64GA13-170	600	600	600	600	600	600	–	–			
			900#		64GA14-170	900	900	900	900	900	900	–	–			
			1500#		64GA15-170	1500	1500	1500	1500	1500	1500	–	–			
		1 1/2 x 3	300#	150#	64GA32-170	–	–	–	–	–	300	300	215	Chrome Moly Steel		
			600#		64GA33-170	–	–	–	–	–	600	600	430			
			900#		64GA34-170	–	–	–	–	–	900	900	650			
			1500#		64GA35-170	–	–	–	–	–	1500	1500	1080			
H	0.873	1 1/2 x 3	300#	150#	64HA12-170	300	300	300	300	300	300	–	–	Carbon Steel	Chrome Alloy, Rust Proofed	
			600#		64HA13-170	600	600	600	600	600	600	–	–			
			900#		64HA14-170	900	900	900	900	900	900	–	–			
			1500#		64HA15-170	1500	1500	1500	1500	1500	1500	–	–			
		1 1/2 x 3	300#	150#	64HA32-170	–	–	–	–	–	300	300	215	Chrome Moly Steel		
			600#		64HA33-170	–	–	–	–	–	600	600	430			
			900#		64HA34-170	–	–	–	–	–	900	900	650			
			1500#		64HA35-170	–	–	–	–	–	1500	1500	1080			
J	1.430	2 x 3	300#	150#	64JA12-170	300	300	300	300	300	300	–	–	Carbon Steel	Chrome Alloy, Rust Proofed	
			600#		64JA13-170	600	600	600	600	600	600	600	–			–
		2 1/2 x 4	900#	150#	64JA14-170	900	900	900	900	900	900	900	–	–		Chrome Moly Steel
			1500#		64JA15-170	1500	1500	1500	1500	1500	1500	1500	–	–		
		2 x 3	300#	150#	64JA32-170	–	–	–	–	–	300	300	215	Chrome Moly Steel		
			600#		64JA33-170	–	–	–	–	–	600	600	430			
		2 1/2 x 4	900#	150#	64JA34-170	–	–	–	–	–	900	900	650	Chrome Moly Steel		
			1500#		64JA35-170	–	–	–	–	–	1500	1500	1080			

General Notes:

1. The 6400 Series comes standard with an open bonnet and plain lifting lever.
2. For optional test gag, change the last digit of the three digit type number suffix to "1". Example: 64GA13-171 and 66LA12-141.
3. On certain sizes 150#RF inlet flanges are available. Consult the factory.
4. Available in open lever design only. No plain cap or packed lever construction.
5. For optional ring joint inlet, change the first digit of suffix to "9". Example: 64LA15-970.
6. Consult the factory for set pressures beyond those listed above.
7. Bonnet is carbon steel through 1000 °F.

Selection Table – Series 6400 continued

US Customary System Units															
Orifice		Valve Size Inlet x Outlet	ANSI Flange Class		Type Number	Maximum Set Pressure, psig								Material	
Letter	Area sq. in.		Inlet RF	Outlet RF		300 °F	400 °F	500 °F	600 °F	700 °F	800 °F	900 °F	1000 °F	Body & Bonnet?	Spring
K	2.042	2 1/2 x 4	300#	150#	64KA12-170	300	300	300	300	300	300	–	–	Carbon Steel	Chrome Alloy, Rust Proofed
			600#		64KA13-170	600	600	600	600	600	600	–	–		
			900#		64KA14-170	900	900	900	900	900	900	–	–		
			1500#		64KA15-170	1500	1500	1500	1500	1500	1500	–	–		
	2 1/2 x 4	300#	64KA32-170	–	–	–	–	–	–	300	300	215	Chrome Moly Steel		
		600#	64KA33-170	–	–	–	–	–	–	600	600	430			
		900#	64KA34-170	–	–	–	–	–	–	900	900	650			
		1500#	64KA35-170	–	–	–	–	–	–	1500	1500	1080			
L	3.170	3 x 6	300#	150#	64LA12-170	300	300	300	300	300	300	–	–	Carbon Steel	Chrome Alloy, Rust Proofed
			600#		64LA13-170	600	600	600	600	600	600	–	–		
			900#		64LA14-170	900	900	900	900	900	900	–	–		
			1500#		64LA15-170	1500	1500	1500	1500	1500	1500	–	–		
	3 x 6	300#	64LA32-170	–	–	–	–	–	–	300	300	215	Chrome Moly Steel		
		600#	64LA33-170	–	–	–	–	–	–	600	600	430			
		900#	64LA34-170	–	–	–	–	–	–	900	900	650			
		1500#	64LA35-170	–	–	–	–	–	–	1500	1500	1080			
M	4.000	3 x 6	300#	150#	64MA12-170	300	300	300	300	300	300	–	–	Carbon Steel	Chrome Alloy, Rust Proofed
			600#		64MA13-170	600	600	600	600	600	600	–	–		
			900#		64MA14-170	900	900	900	900	900	900	–	–		
			1500#		64MA15-170	1500	1500	1500	1500	1500	1500	–	–		
	3 x 6	300#	64MA32-170	–	–	–	–	–	–	300	300	215	Chrome Moly Steel		
		600#	64MA33-170	–	–	–	–	–	–	600	600	430			
		900#	64MA34-170	–	–	–	–	–	–	900	900	650			
		1500#	64MA35-170	–	–	–	–	–	–	1500	1500	1080			
N	4.822	4 x 6	300#	150#	64NA12-170	300	300	300	300	300	300	–	–	Carbon Steel	Chrome Alloy, Rust Proofed
			600#		64NA13-170	600	600	600	600	600	600	–	–		
			900#		64NA14-170	900	900	900	900	900	900	–	–		
			300#		64NA32-170	–	–	–	–	–	–	300	300		
	600#	64NA33-170	–	–	–	–	–	–	600	600	430				
	900#	64NA34-170	–	–	–	–	–	–	900	900	650				
	300#	64PA12-170	300	300	300	300	300	300	300	–	–	Carbon Steel	Chrome Alloy, Rust Proofed		
	600#	64PA13-170	600	600	600	600	600	600	600	–	–				
900#	64PA14-170	900	900	900	900	900	900	900	–	–					
300#	64PA32-170	–	–	–	–	–	–	–	300	300	215			Chrome Moly Steel	
600#	64PA33-170	–	–	–	–	–	–	–	600	600	430				
900#	64PA34-170	–	–	–	–	–	–	–	900	900	650				

Selection Table – Series 6400

Metric System Units																
Orifice		Valve Size Inlet x Outlet	ANSI Flange Class		Type Number	Maximum Set Pressure, barg								Material		
Letter	Area mm ²		Inlet RF	Outlet RF		149 °C	204 °C	260 °C	316 °C	371 °C	427 °C	482 °C	538 °C	Body & Bonnet ⁷	Spring	
D	97	1 x 2	300#	150#	64DA12-170	20.7	20.7	20.7	20.7	20.7	20.7	–	–	Carbon Steel	Chrome Alloy, Rust Proofed	
			600#		64DA13-170	41.3	41.3	41.3	41.3	41.3	41.3	–	–			
			900#		64DA14-170	62.0	62.0	62.0	62.0	62.0	62.0	–	–			
			1500#		64DA15-170	103	103	103	103	103	103	–	–			
	97	1 x 2	300#	150#	64DA32-170	–	–	–	–	–	20.7	20.7	14.9	Chrome Moly Steel	Chrome Alloy, Rust Proofed	
			600#		64DA33-170	–	–	–	–	–	41.3	41.3	29.8			
			900#		64DA34-170	–	–	–	–	–	62.0	62.0	44.7			
			1500#		64DA35-170	–	–	–	–	–	103	103	74.5			
E	145	1 x 2	300#	150#	64EA12-170	20.7	20.7	20.7	20.7	20.7	20.7	–	–	Carbon Steel	Chrome Alloy, Rust Proofed	
			600#		64EA13-170	41.3	41.3	41.3	41.3	41.3	41.3	–	–			
			900#		64EA14-170	62.0	62.0	62.0	62.0	62.0	62.0	–	–			
			1500#		64EA15-170	103	103	103	103	103	103	–	–			
	145	1 x 2	300#	150#	64EA32-170	–	–	–	–	–	20.7	20.7	14.9	Chrome Moly Steel	Chrome Alloy, Rust Proofed	
			600#		64EA33-170	–	–	–	–	–	41.3	41.3	29.8			
			900#		64EA34-170	–	–	–	–	–	62.0	62.0	44.7			
			1500#		64EA35-170	–	–	–	–	–	103	103	74.5			
F	239	1 1/2 x 2	300#	150#	64FA12-170	20.7	20.7	20.7	20.7	20.7	20.7	–	–	Carbon Steel	Chrome Alloy, Rust Proofed	
			600#		64FA13-170	41.3	41.3	41.3	41.3	41.3	41.3	–	–			
			900#		64FA14-170	62.0	62.0	62.0	62.0	62.0	62.0	–	–			
			1500#		64FA15-170	103	103	103	103	103	103	–	–			
	239	1 1/2 x 2	300#	150#	64FA32-170	–	–	–	–	–	20.7	20.7	14.9	Chrome Moly Steel	Chrome Alloy, Rust Proofed	
			600#		64FA33-170	–	–	–	–	–	41.3	41.3	29.8			
			900#		64FA34-170	–	–	–	–	–	62.0	62.0	44.7			
			1500#		64FA35-170	–	–	–	–	–	103	103	74.5			
G	361	1 1/2 x 3	300#	150#	64GA12-170	20.7	20.7	20.7	20.7	20.7	20.7	–	–	Carbon Steel	Chrome Alloy, Rust Proofed	
			600#		64GA13-170	41.3	41.3	41.3	41.3	41.3	41.3	–	–			
			900#		64GA14-170	62.0	62.0	62.0	62.0	62.0	62.0	–	–			
			1500#		64GA15-170	103	103	103	103	103	103	–	–			
	361	1 1/2 x 3	300#	150#	64GA32-170	–	–	–	–	–	20.7	20.7	14.9	Chrome Moly Steel	Chrome Alloy, Rust Proofed	
			600#		64GA33-170	–	–	–	–	–	41.3	41.3	29.8			
			900#		64GA34-170	–	–	–	–	–	62.0	62.0	44.7			
			1500#		64GA35-170	–	–	–	–	–	103	103	74.5			
H	563	1 1/2 x 3	300#	150#	64HA12-170	20.7	20.7	20.7	20.7	20.7	20.7	–	–	Carbon Steel	Chrome Alloy, Rust Proofed	
			600#		64HA13-170	41.3	41.3	41.3	41.3	41.3	41.3	–	–			
			900#		64HA14-170	62.0	62.0	62.0	62.0	62.0	62.0	–	–			
			1500#		64HA15-170	103	103	103	103	103	103	–	–			
	563	1 1/2 x 3	300#	150#	64HA32-170	–	–	–	–	–	20.7	20.7	14.9	Chrome Moly Steel	Chrome Alloy, Rust Proofed	
			600#		64HA33-170	–	–	–	–	–	41.3	41.3	29.8			
			900#		64HA34-170	–	–	–	–	–	62.0	62.0	44.7			
			1500#		64HA35-170	–	–	–	–	–	103	103	74.5			
J	923	2 x 3	300#	150#	64JA12-170	20.7	20.7	20.7	20.7	20.7	20.7	–	–	Carbon Steel	Chrome Alloy, Rust Proofed	
			600#		64JA13-170	41.3	41.3	41.3	41.3	41.3	41.3	41.3	–			–
		2 1/2 x 4	900#	150#	64JA14-170	62.0	62.0	62.0	62.0	62.0	62.0	62.0	–			–
			1500#		64JA15-170	103	103	103	103	103	103	103	–			–
	923	2 x 3	300#	150#	64JA32-170	–	–	–	–	–	20.7	20.7	14.9	Chrome Moly Steel	Chrome Alloy, Rust Proofed	
			600#		64JA33-170	–	–	–	–	–	41.3	41.3	29.8			
	2 1/2 x 4	900#	150#	64JA34-170	–	–	–	–	–	62.0	62.0	44.7				
		1500#		64JA35-170	–	–	–	–	–	103	103	74.5				

General Notes:

1. The 6400 Series comes standard with an open yoke and plain lifting lever.
2. For optional test gag, change the last digit of the three digit type number suffix to "1". Example: 64GA13-171 and 66LA12-141.
3. On certain sizes 150#RF inlet flanges are available. Consult the Factory.
4. Available in open lever design only. No plain cap or packed lever construction.
5. For optional ring joint inlet, change the first digit of suffix to "9". Example: 64LA15-970.
6. Consult the factory for set pressures beyond those listed above.
7. Bonnet is carbon steel through 538 °C.

Selection Table – Series 6400 continued

Metric System Units															
Orifice		Valve Size Inlet x Outlet	ANSI Flange Class		Type Number	Maximum Set Pressure, barg								Material	
Letter	Area mm ²		Inlet RF	Outlet RF		149 °C	204 °C	260 °C	316 °C	371 °C	427 °C	482 °C	538 °C	Body & Bonnet ⁷	Spring
K	1317	2 1/2 x 4	300#	150#	64KA12-170	20.7	20.7	20.7	20.7	20.7	20.7	–	–	Carbon Steel	Chrome Alloy, Rust Proofed
			600#		64KA13-170	41.3	41.3	41.3	41.3	41.3	41.3	–	–		
			900#		64KA14-170	62.0	62.0	62.0	62.0	62.0	62.0	–	–		
			1500#		64KA15-170	103	103	103	103	103	103	–	–		
	2 1/2 x 4	300#	64KA32-170	–	–	–	–	–	–	20.7	20.7	14.9	Chrome Moly Steel		
		600#	64KA33-170	–	–	–	–	–	–	41.3	41.3	29.8			
		900#	64KA34-170	–	–	–	–	–	–	62.0	62.0	44.7			
		1500#	64KA35-170	–	–	–	–	–	–	103	103	74.5			
L	2045	3 x 6	300#	150#	64LA12-170	20.7	20.7	20.7	20.7	20.7	20.7	–	–	Carbon Steel	Chrome Alloy, Rust Proofed
			600#		64LA13-170	41.3	41.3	41.3	41.3	41.3	41.3	–	–		
			900#		64LA14-170	62.0	62.0	62.0	62.0	62.0	62.0	–	–		
			1500#		64LA15-170	103	103	103	103	103	103	–	–		
	3 x 6	300#	64LA32-170	–	–	–	–	–	–	20.7	20.7	14.9	Chrome Moly Steel		
		600#	64LA33-170	–	–	–	–	–	–	41.3	41.3	29.8			
		900#	64LA34-170	–	–	–	–	–	–	62.0	62.0	44.7			
		1500#	64LA35-170	–	–	–	–	–	–	103	103	74.5			
M	2581	3 x 6	300#	150#	64MA12-170	20.7	20.7	20.7	20.7	20.7	20.7	–	–	Carbon Steel	Chrome Alloy, Rust Proofed
			600#		64MA13-170	41.3	41.3	41.3	41.3	41.3	41.3	–	–		
			900#		64MA14-170	62.0	62.0	62.0	62.0	62.0	62.0	–	–		
			1500#		64MA15-170	103	103	103	103	103	103	–	–		
	3 x 6	300#	64MA32-170	–	–	–	–	–	–	20.7	20.7	14.9	Chrome Moly Steel		
		600#	64MA33-170	–	–	–	–	–	–	41.3	41.3	29.8			
		900#	64MA34-170	–	–	–	–	–	–	62.0	62.0	44.7			
		1500#	64MA35-170	–	–	–	–	–	–	103	103	74.5			
N	3111	4 x 6	300#	150#	64NA12-170	20.7	20.7	20.7	20.7	20.7	20.7	–	–	Carbon Steel	Chrome Alloy, Rust Proofed
			600#		64NA13-170	41.3	41.3	41.3	41.3	41.3	41.3	–	–		
			900#		64NA14-170	62.0	62.0	62.0	62.0	62.0	62.0	–	–		
			300#		64NA32-170	–	–	–	–	–	–	20.7	20.7		
	600#	64NA33-170	–	–	–	–	–	–	41.3	41.3	29.8				
	900#	64NA34-170	–	–	–	–	–	–	62.0	62.0	44.7				
	300#	64PA12-170	20.7	20.7	20.7	20.7	20.7	20.7	20.7	–	–	Carbon Steel	Chrome Alloy, Rust Proofed		
	600#	64PA13-170	41.3	41.3	41.3	41.3	41.3	41.3	41.3	–	–				
900#	64PA14-170	62.0	62.0	62.0	62.0	62.0	62.0	62.0	–	–					
300#	64PA32-170	–	–	–	–	–	–	–	20.7	20.7	14.9			Chrome Moly Steel	
600#	64PA33-170	–	–	–	–	–	–	–	41.3	41.3	29.8				
900#	64PA34-170	–	–	–	–	–	–	–	62.0	62.0	44.7				

Selection Table – Series 6600

US Customary System Units														
Orifice		Valve Size Inlet x Outlet	ANSI Flange Class		Type Number	Maximum Set Pressure, psig						Max. Back Press. psig at 100 °F	Material	
Letter	Area sq. in.		Inlet RF	Outlet RF		300 °F	400 °F	500 °F	600 °F	700 °F	800 °F		Body & Bonnet	Spring
D	0.150	1 x 2	300#	150#	66DA12-140	300	300	300	300	300	300	285	Carbon Steel	Chrome Alloy, Rust Proofed
			600#		66DA13-140	600	600	600	600	600	600			
			900#		66DA14-140	900	900	900	900	900	900			
			1500#		66DA15-140	1500	1500	1500	1500	1500	1500			
E	0.225	1 x 2	300#	150#	66EA12-140	300	300	300	300	300	300	285	Carbon Steel	Chrome Alloy, Rust Proofed
			600#		66EA13-140	600	600	600	600	600	600			
			900#		66EA14-140	900	900	900	900	900	900			
			1500#		66EA15-140	1500	1500	1500	1500	1500	1500			
F	0.371	1 1/2 x 2	300#	150#	66FA12-140	300	300	300	300	300	300	285	Carbon Steel	Chrome Alloy, Rust Proofed
			600#		66FA13-140	600	600	600	600	600	600			
			900#		66FA14-140	900	900	900	900	900	900			
			1500#		66FA15-140	1500	1500	1500	1500	1500	1500			
G	0.559	1 1/2 x 3	300#	150#	66GA12-140	300	300	300	300	300	300	285	Carbon Steel	Chrome Alloy, Rust Proofed
			600#		66GA13-140	600	600	600	600	600	600			
			900#		66GA14-140	900	900	900	900	900	900			
			1500#		66GA15-140	1500	1500	1500	1500	1500	1500			
H	0.873	1 1/2 x 3	300#	150#	66HA12-140	300	300	300	300	300	300	285	Carbon Steel	Chrome Alloy, Rust Proofed
			600#		66HA13-140	600	600	600	600	600	600			
			900#		66HA14-140	900	900	900	900	900	900			
			1500#		66HA15-140	1500	1500	1500	1500	1500	1500			
J	1.430	2 x 3	300#	150#	66JA12-140	300	300	300	300	300	285	Carbon Steel	Chrome Alloy, Rust Proofed	
			600#		66JA13-140	600	600	600	600	600				
		2 1/2 x 4	900#	150#	66JA14-140	900	900	900	900	900				900
			1500#		66JA15-140	1500	1500	1500	1500	1500				1500
K	2.042	2 1/2 x 4	300#	150#	66KA12-140	300	300	300	300	300	300	285	Carbon Steel	Chrome Alloy, Rust Proofed
			600#		66KA13-140	600	600	600	600	600	600			
			900#		66KA14-140	900	900	900	900	900	900			
			1500#		66KA15-140	1500	1500	1500	1500	1500	1500			
L	3.170	3 x 6	300#	150#	66LA12-140	300	300	300	300	300	300	285	Carbon Steel	Chrome Alloy, Rust Proofed
			600#		66LA13-140	600	600	600	600	600	600			
			900#		66LA14-140	900	900	900	900	900	900			
			1500#		66LA15-140	1500	1500	1500	1500	1500	1500			
M	4.000	3 x 6	300#	150#	66MA12-140	300	300	300	300	300	300	285	Carbon Steel	Chrome Alloy, Rust Proofed
			600#		66MA13-140	600	600	600	600	600	600			
			900#		66MA14-140	900	900	900	900	900	900			
			1500#		66MA15-140	1500	1500	1500	1500	1500	1500			
N	4.822	4 x 6	300#	150#	66NA12-140	300	300	300	300	300	285	Carbon Steel	Chrome Alloy, Rust Proofed	
			600#		66NA13-140	600	600	600	600	600				600
			900#		66NA14-140	900	900	900	900	900				900
P	7.087	4 x 6	300#	150#	66PA12-140	300	300	300	300	300	285	Carbon Steel	Chrome Alloy, Rust Proofed	
			600#		66PA13-140	600	600	600	600	600				600
			900#		66PA14-140	900	900	900	900	900				900

General Notes:

1. The 6600 Series comes standard with enclosed spring and packed lifting lever.
2. For organic fluid vaporizer service, add "D" to the type number and specify a plain screwed cap. Example: 66NA12D-120.
3. On certain sizes, 150#RF inlet flanges are available. Consult the Factory.
4. For optional ring joint inlet, change the first digit of suffix to "9". Example: 66EA15-920.
5. Consult the factory for set pressures beyond those listed above.

Selection Table – Series 6600

Metric System Units														
Orifice		Valve Size Inlet x Outlet	ANSI Flange Class		Type Number	Maximum Set Pressure, barg						Max. Back Press. barg at 38 °C	Material	
Letter	Area mm ²		Inlet RF	Outlet RF		149 °C	204 °C	260 °C	316 °C	371 °C	427 °C		Body & Bonnet	Spring
D	97	1 x 2	300#	150#	66DA12-140	20.7	20.7	20.7	20.7	20.7	20.7	19.6	Carbon Steel	Chrome Alloy, Rust Proofed
			600#		66DA13-140	41.3	41.3	41.3	41.3	41.3	41.3			
			900#		66DA14-140	62.0	62.0	62.0	62.0	62.0	62.0			
			1500#		66DA15-140	103	103	103	103	103	103			
E	145	1 x 2	300#	150#	66EA12-140	20.7	20.7	20.7	20.7	20.7	20.7	19.6	Carbon Steel	Chrome Alloy, Rust Proofed
			600#		66EA13-140	41.3	41.3	41.3	41.3	41.3	41.3			
			900#		66EA14-140	62.0	62.0	62.0	62.0	62.0	62.0			
			1500#		66EA15-140	103	103	103	103	103	103			
F	239	1 1/2 x 2	300#	150#	66FA12-140	20.7	20.7	20.7	20.7	20.7	20.7	19.6	Carbon Steel	Chrome Alloy, Rust Proofed
			600#		66FA13-140	41.3	41.3	41.3	41.3	41.3	41.3			
			900#		66FA14-140	62.0	62.0	62.0	62.0	62.0	62.0			
			1500#		66FA15-140	103	103	103	103	103	103			
G	361	1 1/2 x 3	300#	150#	66GA12-140	20.7	20.7	20.7	20.7	20.7	20.7	19.6	Carbon Steel	Chrome Alloy, Rust Proofed
			600#		66GA13-140	41.3	41.3	41.3	41.3	41.3	41.3			
			900#		66GA14-140	62.0	62.0	62.0	62.0	62.0	62.0			
			1500#		66GA15-140	103	103	103	103	103	103			
H	563	1 1/2 x 3	300#	150#	66HA12-140	20.7	20.7	20.7	20.7	20.7	20.7	19.6	Carbon Steel	Chrome Alloy, Rust Proofed
			600#		66HA13-140	41.3	41.3	41.3	41.3	41.3	41.3			
			900#		66HA14-140	62.0	62.0	62.0	62.0	62.0	62.0			
			1500#		66HA15-140	103	103	103	103	103	103			
J	923	2 x 3	150#	66JA12-140	20.7	20.7	20.7	20.7	20.7	20.7	19.6	Carbon Steel	Chrome Alloy, Rust Proofed	
		600#		66JA13-140	41.3	41.3	41.3	41.3	41.3	41.3				
		2 1/2 x 4	150#	66JA14-140	62.0	62.0	62.0	62.0	62.0	62.0				
		900#		66JA15-140	103	103	103	103	103	103				
K	1317	2 1/2 x 4	300#	150#	66KA12-140	20.7	20.7	20.7	20.7	20.7	20.7	19.6	Carbon Steel	Chrome Alloy, Rust Proofed
			600#		66KA13-140	41.3	41.3	41.3	41.3	41.3	41.3			
			900#		66KA14-140	62.0	62.0	62.0	62.0	62.0	62.0			
			1500#		66KA15-140	103	103	103	103	103	103			
L	2045	3 x 6	300#	150#	66LA12-140	20.7	20.7	20.7	20.7	20.7	20.7	19.6	Carbon Steel	Chrome Alloy, Rust Proofed
			600#		66LA13-140	41.3	41.3	41.3	41.3	41.3	41.3			
			900#		66LA14-140	62.0	62.0	62.0	62.0	62.0	62.0			
			1500#		66LA15-140	103	103	103	103	103	103			
M	2581	3 x 6	300#	150#	66MA12-140	20.7	20.7	20.7	20.7	20.7	20.7	19.6	Carbon Steel	Chrome Alloy, Rust Proofed
			600#		66MA13-140	41.3	41.3	41.3	41.3	41.3	41.3			
			900#		66MA14-140	62.0	62.0	62.0	62.0	62.0	62.0			
			1500#		66MA15-140	103	103	103	103	103	103			
N	3111	4 x 6	300#	150#	66NA12-140	20.7	20.7	20.7	20.7	20.7	20.7	19.6	Carbon Steel	Chrome Alloy, Rust Proofed
			600#		66NA13-140	41.3	41.3	41.3	41.3	41.3	41.3			
			900#		66NA14-140	62.0	62.0	62.0	62.0	62.0	62.0			
P	4572	4 x 6	300#	150#	66PA12-140	20.7	20.7	20.7	20.7	20.7	20.7	19.6	Carbon Steel	Chrome Alloy, Rust Proofed
			600#		66PA13-140	41.3	41.3	41.3	41.3	41.3	41.3			
			900#		66PA14-140	62.0	62.0	62.0	62.0	62.0	62.0			

General Notes:

1. The 6600 Series comes standard with enclosed spring and packed lifting lever.
2. For organic fluid vaporizer service, add "D" to the type number and specify a plain screwed cap. Example: 66NA12D-120.
3. On certain sizes, 150#RF inlet flanges are available. Consult the factory.
4. For optional ring joint inlet, change the first digit of suffix to "9". Example: 66EA15-920.
5. Consult the factory for set pressures beyond those listed above.

Steam Capacities – 6400 & 6600 Series: 3% Overpressure

US Customary System Units

ASME Pressure Vessel Code Section I, (V) Stamp: Capacities in Pounds per Hour at Saturation Temperature											
Set Pressure (psig)	Orifice Letter Designations & Areas, Square Inches										
	D	E	F	G	H	J	K	L	M	N	P
	0.150	0.225	0.371	0.559	0.873	1.430	2.042	3.170	4.000	4.822	7.087
15	210	315	519	783	1222	2003	2860	4440	5602	6754	9926
20	243	364	601	906	1415	2318	3311	5140	6486	7819	11492
40	375	563	929	1400	2187	3582	5116	7942	10021	12081	17755
60	508	762	1257	1894	2958	4846	6920	10743	13556	16342	24018
80	643	965	1591	2398	3745	6135	8761	13601	17162	20689	30407
100	780	1170	1929	2907	4540	7437	10620	16486	20803	25078	36858
120	916	1374	2267	3416	5334	8738	12478	19372	24444	29467	43309
140	1053	1579	2604	3924	6129	10040	14337	22257	28085	33856	49760
160	1189	1784	2942	4433	6924	11342	16196	25143	31726	38246	56211
180	1326	1989	3280	4942	7718	12643	18054	28028	35367	42635	62661
200	1462	2194	3618	5451	8513	13945	19913	30914	39008	47024	69112
220	1599	2399	3955	5960	9308	15247	21772	33799	42649	51413	75563
240	1735	2603	4293	6469	10102	16548	23631	36685	46290	55802	82014
260	1872	2808	4631	6977	10897	17850	25489	39570	49931	60192	88465
280	2008	3013	4968	7486	11692	19152	27348	42456	53572	64581	94916
300	2145	3218	5306	7995	12486	20453	29207	45341	57213	68970	101367
320	2282	3423	5644	8504	13281	21755	31066	48227	60854	73359	107818
340	2418	3627	5981	9013	14076	23057	32924	51112	64495	77749	114269
360	2555	3832	6319	9522	14870	24358	34783	53998	68136	82138	120720
380	2691	4037	6657	10030	15665	25660	36642	56883	71777	86527	127171
400	2828	4242	6995	10539	16460	26962	38501	59769	75418	90916	133622
420	2964	4447	7332	11048	17254	28263	40359	62654	79059	95306	140073
440	3101	4651	7670	11557	18049	29565	42218	65540	82700	99695	146524
460	3237	4856	8008	12066	18844	30867	44077	68425	86341	104084	152975
480	3374	5061	8345	12575	19638	32168	45936	71311	89982	108473	159426
500	3510	5266	8683	13083	20433	33470	47794	74196	93623	112863	165877
520	3647	5471	9021	13592	21227	34772	49653	77082	97264	117252	172328
540	3783	5675	9358	14101	22022	36073	51512	79967	100905	121641	178779
560	3920	5880	9696	14610	22817	37375	53370	82853	104546	126030	185230
580	4057	6085	10034	15119	23611	38677	55229	85738	108187	130419	191681
600	4193	6290	10372	15628	24406	39978	57088	88624	111828	134809	198132
620	4330	6495	10709	16136	25201	41280	58947	91509	115469	139198	204583
640	4466	6699	11047	16645	25995	42581	60805	94395	119110	143587	211033
660	4603	6904	11385	17154	26790	43883	62664	97280	122751	147976	217484
680	4739	7109	11722	17663	27585	45185	64523	100166	126392	152366	223935
700	4876	7314	12060	18172	28379	46486	66382	103051	130033	156755	230386
720	5012	7519	12398	18681	29174	47788	68240	105937	133674	161144	236837
740	5149	7723	12736	19189	29969	49090	70099	108822	137315	165533	243288
760	5285	7928	13073	19698	30763	50391	71958	111708	140956	169923	249739
780	5422	8133	13411	20207	31558	51693	73817	114593	144597	174312	256190
800	5558	8338	13749	20716	32353	52995	75675	117479	148238	178701	262641
820	5695	8543	14086	21225	33147	54296	77534	120364	151879	183090	269092
840	5832	8748	14424	21733	33942	55598	79393	123250	155520	187480	275543
860	5968	8952	14762	22242	34737	56900	81251	126135	159161	191869	281994
880	6105	9157	15099	22751	35531	58201	83110	129021	162802	196258	288445
900	6241	9362	15437	23260	36326	59503	84969	131906	166443	200647	294896
920	6378	9567	15775	23769	37120	60805	86828	134792	170084	-	-
940	6514	9772	16113	24278	37915	62106	88686	137677	173725	-	-
960	6651	9976	16450	24786	38710	63408	90545	140563	177366	-	-
980	6787	10181	16788	25295	39504	64710	92404	143448	181007	-	-
1000	6924	10386	17126	25804	40299	66011	94263	146334	184648	-	-
1100	7607	11410	18814	28348	44272	72520	103556	160761	202853	-	-
1200	8289	12434	20503	30892	48246	79028	112850	175189	221058	-	-
1300	8972	13458	22191	33437	52219	85536	122144	189616	239263	-	-
1400	9655	14482	23880	35981	56192	92045	131437	204044	257468	-	-
1500	10337	15506	25568	38525	60165	98553	140731	218471	275673	-	-

Steam Capacities – 6400 & 6600 Series: 10% Overpressure

US Customary System Units

ASME Pressure Vessel Code Section VIII, (UV) Stamp: Capacities in pounds per Hour at Saturation Temperature											
Set Pressure (psig)	Orifice Letter Designations & Areas, Square Inches										
	D	E	F	G	H	J	K	L	M	N	P
	0.150	0.225	0.371	0.559	0.873	1.430	2.042	3.170	4.000	4.822	7.087
15	216	325	536	807	1261	2066	2950	4580	5779	6967	10240
20	249	374	618	931	1454	2382	3401	5280	6663	8032	11805
40	389	583	962	1449	2264	3709	5296	8222	10375	12507	18382
60	534	802	1322	1993	3113	5099	7281	11303	14263	17194	25271
80	680	1021	1683	2536	3961	6489	9266	14385	18152	21882	32160
100	826	1239	2044	3080	4810	7879	11251	17467	22040	26569	39050
120	972	1458	2404	3623	5658	9269	13236	20548	25928	31257	45939
140	1118	1677	2765	4166	6507	10659	15221	23630	29817	35944	52828
160	1263	1895	3126	4710	7356	12049	17206	26711	33705	40632	59718
180	1409	2114	3486	5253	8204	13439	19191	29793	37594	45319	66607
200	1555	2333	3847	5797	9053	14830	21176	32875	41482	50007	73497
220	1701	2552	4208	6340	9902	16220	23162	35956	45371	54694	80386
240	1847	2770	4568	6884	10750	17610	25147	39038	49259	59382	87275
260	1993	2989	4929	7427	11599	19000	27132	42119	53148	64070	94165
280	2138	3208	5290	7970	12448	20390	29117	45201	57036	68757	101054
300	2284	3427	5650	8514	13296	21780	31102	48283	60925	73445	107943
320	2430	3645	6011	9057	14145	23170	33087	51364	64813	78132	114833
340	2576	3864	6372	9601	14994	24560	35072	54446	68701	82820	121722
360	2722	4083	6732	10144	15842	25951	37057	57527	72590	87507	128612
380	2867	4301	7093	10687	16691	27341	39042	60609	76478	92195	135501
400	3013	4520	7454	11231	17540	28731	41027	63691	80367	96882	142390
420	3159	4739	7814	11774	18388	30121	43012	66772	84255	101570	149280
440	3305	4958	8175	12318	19237	31511	44997	69854	88144	106257	156169
460	3451	5176	8536	12861	20086	32901	46982	72935	92032	110945	163058
480	3597	5395	8896	13404	20934	34291	48967	76017	95921	115632	169948
500	3742	5614	9257	13948	21783	35681	50952	79099	99809	120320	176837
520	3888	5833	9617	14491	22632	37072	52937	82180	103698	125008	183727
540	4034	6051	9978	15035	23480	38462	54922	85262	107586	129695	190616
560	4180	6270	10339	15578	24329	39852	56907	88343	111474	134383	197505
580	4326	6489	10699	16122	25178	41242	58893	91425	115363	139070	204395
600	4471	6707	11060	16665	26026	42632	60878	94507	119251	143758	211284
620	4617	6926	11421	17208	26875	44022	62863	97588	123140	148445	218173
640	4763	7145	11781	17752	27724	45412	64848	100670	127028	153133	225063
660	4909	7364	12142	18295	28572	46802	66833	103751	130917	157820	231952
680	5055	7582	12503	18839	29421	48193	68818	106833	134805	162508	238841
700	5201	7801	12863	19382	30269	49583	70803	109915	138694	167195	245731
720	5346	8020	13224	19925	31118	50973	72788	112996	142582	171883	252620
740	5492	8238	13585	20469	31967	52363	74773	116078	146471	176570	259510
760	5638	8457	13945	21012	32815	53753	76758	119159	150359	181258	266399
780	5784	8676	14306	21556	33664	55143	78743	122241	154247	185945	273288
800	5930	8895	14667	22099	34513	56533	80728	125323	158136	190633	280178
820	6075	9113	15027	22642	35361	57923	82713	128404	162024	195321	287067
840	6221	9332	15388	23186	36210	59314	84698	131486	165913	200008	293956
860	6367	9551	15749	23729	37059	60704	86683	134567	169801	204696	300846
880	6513	9770	16109	24273	37907	62094	88668	137649	173690	209383	307735
900	6659	9988	16470	24816	38756	63484	90653	140731	177578	214071	314625
920	6805	10207	16831	25360	39605	64874	92638	143812	181467	–	–
940	6950	10426	17191	25903	40453	66264	94624	146894	185355	–	–
960	7096	10644	17552	26446	41302	67654	96609	149975	189244	–	–
980	7242	10863	17913	26990	42151	69044	98594	153057	193132	–	–
1000	7388	11082	18273	27533	42999	70435	100579	156139	197020	–	–
1100	8117	12176	20076	30250	47243	77385	110504	171547	216463	–	–
1200	8846	13269	21880	32967	51486	84336	120429	186955	235905	–	–
1300	9575	14363	23683	35684	55729	91286	130355	202363	255347	–	–
1400	10304	15456	25486	38401	59972	98237	140280	217771	274790	–	–
1500	11033	16550	27290	41118	64216	105188	150205	233179	294232	–	–

General Notes:

1. The 6400 Series is also Section VIII certified for air & gas service, for Air capacities at 10% overpressure contact factory.

Steam Capacities – 6400 & 6600 Series: 3% Overpressure

Metric System Units

ASME Pressure Vessel Code Section I, (V) Stamp: Capacities in Kilograms per Hour at Saturation Temperature											
Set Pressure (barg)	Orifice Letter Designations & Areas, sq. mm										
	D	E	F	G	H	J	K	L	M	N	P
	97	145	239	361	563	923	1317	2045	2581	3111	4572
1	93	141	232	349	546	894	1277	1982	2502	3016	4432
2	137	206	340	512	800	1310	1871	2904	3664	4417	6492
3	181	271	448	675	1053	1725	2464	3826	4827	5819	8553
4	225	337	555	837	1307	2141	3058	4747	5990	7221	10613
5	269	403	665	1002	1564	2562	3659	5680	7167	8640	12698
6	313	470	776	1169	1825	2990	4270	6629	8364	10084	14820
7	358	538	887	1336	2087	3418	4882	7578	9562	11527	16942
8	403	605	998	1504	2348	3847	5493	8527	10760	12971	19064
9	448	672	1109	1671	2610	4275	6104	9477	11958	14415	21186
10	493	740	1220	1838	2871	4703	6716	10426	13155	15859	23308
11	538	807	1331	2006	3133	5131	7327	11375	14353	17303	25430
12	583	875	1442	2173	3394	5559	7938	12324	15551	18747	27553
13	628	942	1553	2341	3655	5988	8550	13273	16749	20191	29675
14	673	1009	1664	2508	3916	6416	9161	14222	17946	21634	31796
15	718	1077	1775	2675	4178	6844	9773	15172	19144	23078	33918
16	763	1144	1887	2843	4439	7272	10384	16121	20342	24522	36041
17	807	1212	1998	3010	4701	7700	10996	17070	21540	25966	38163
18	852	1279	2109	3177	4962	8129	11607	18019	22737	27410	40285
19	897	1346	2220	3345	5224	8557	12219	18968	23935	28853	42407
20	942	1413	2331	3512	5485	8985	12830	19918	25133	30297	44529
21	987	1481	2442	3680	5746	9413	13442	20867	26330	31741	46651
22	1032	1548	2553	3847	6008	9841	14053	21816	27528	33185	48773
23	1077	1616	2664	4014	6269	10270	14664	22765	28726	34629	50895
24	1122	1683	2775	4182	6530	10697	15276	23714	29924	36073	53017
25	1167	1750	2886	4349	6792	11125	15887	24664	31121	37516	55139
26	1212	1818	2997	4516	7053	11554	16499	25613	32319	38961	57261
27	1256	1885	3109	4684	7315	11982	17110	26562	33517	40404	59383
28	1301	1952	3220	4851	7576	12410	17722	27511	34714	41848	61505
29	1346	2020	3331	5019	7838	12838	18333	28460	35912	43292	63627
30	1391	2087	3442	5186	8099	13266	18945	29409	37109	44736	65749
31	1436	2155	3553	5353	8360	13695	19556	30359	38307	46180	67871
32	1481	2222	3664	5521	8622	14123	20167	31308	39505	47623	69993
33	1526	2289	3775	5688	8883	14551	20779	32257	40703	49067	72116
34	1571	2357	3886	5856	9145	14979	21390	33206	41900	50511	74238
35	1616	2424	3997	6023	9406	15407	22001	34155	43098	51955	76359
36	1661	2492	4108	6190	9668	15836	22613	35105	44296	53399	78481
37	1706	2559	4219	6358	9929	16264	23224	36053	45494	54843	80604
38	1751	2626	4331	6525	10190	16692	23836	37003	46691	56286	82726
39	1796	2693	4442	6692	10451	17120	24447	37952	47889	57731	84848
40	1841	2761	4553	6860	10713	17548	25059	38901	49087	59174	86970
41	1886	2828	4663	7027	10974	17977	25670	39851	50285	60618	89092
42	1931	2896	4775	7195	11236	18405	26282	40800	51482	62062	91214
43	1975	2963	4886	7362	11497	18833	26893	41749	52680	63506	93336
44	2020	3031	4997	7529	11759	19261	27504	42698	53878	64950	95458
45	2065	3098	5108	7697	12020	19689	28116	43647	55075	66393	97580
46	2110	3165	5219	7864	12281	20118	28727	44597	56273	67837	99702
47	2155	3232	5330	8031	12543	20546	29339	45546	57471	69281	101824
48	2200	3300	5441	8199	12804	20974	29950	46495	58669	70725	103946
49	2245	3367	5553	8366	13065	21402	30562	47444	59866	72169	106068
50	2290	3435	5664	8534	13327	21830	31173	48393	61064	73612	108190
52	2380	3569	5885	8868	13850	22686	32396	50292	63460	76500	112434
54	2469	3704	6108	9203	14373	23543	33619	52190	65855	79388	116679
56	2559	3839	6330	9538	14895	24399	34841	54088	68250	82276	120923
58	2649	3974	6552	9873	15418	25256	36064	55986	70645	85163	125166
60	2739	4108	6775	10207	15941	26112	37287	57885	73041	88051	129411
62	2829	4243	6996	10542	16464	26968	38510	59784	75436	90939	133655
64	2918	4378	7219	10877	16986	27825	39733	61682	77832	-	-
66	3008	4512	7441	11212	17509	28681	40956	63580	80227	-	-
68	3098	4647	7663	11546	18032	29538	42179	65479	82623	-	-
70	3188	4782	7885	11881	18555	30394	43402	67377	85018	-	-
72	3278	4917	8107	12216	19078	31250	44625	69275	87414	-	-
74	3368	5052	8329	12551	19601	32107	45848	71173	89809	-	-
76	3457	5186	8552	12885	20124	32963	47070	73072	92205	-	-
78	3547	5321	8774	13220	20646	33820	48293	74971	94600	-	-
80	3637	5456	8996	13555	21169	34675	49516	76869	96995	-	-
85	3861	5792	9551	14392	22476	36816	52573	81615	102984	-	-
90	4086	6129	10107	15229	23783	38957	55630	86360	108972	-	-
95	4311	6467	10662	16066	25090	41098	58688	91106	114961	-	-
100	4536	6803	11218	16902	26397	43239	61744	95852	120950	-	-
103	4670	7005	11551	17405	27181	44524	63579	98700	124543	-	-

Steam Capacities – 6400 & 6600 Series: 10% Overpressure

Metric System Units

ASME Pressure Vessel Code Section VIII, (UV) Stamp: Capacities in Kilograms per Hour at Saturation Temperature											
Set Pressure (barg)	Orifice Letter Designations & Areas, sq. mm										
	D	E	F	G	H	J	K	L	M	N	P
	97	145	239	361	563	923	1317	2045	2581	3111	4572
1	97	145	239	361	563	923	1317	2045	2581	3111	4574
2	140	210	347	523	817	1339	1911	2967	3744	4514	6634
3	188	282	465	701	1095	1793	2561	3975	5015	6046	8886
4	236	354	584	880	1374	2250	3213	4989	6295	7588	11153
5	284	426	702	1058	1653	2708	3866	6002	7574	9131	13419
6	332	498	821	1237	1932	3165	4519	7016	8853	10672	15685
7	380	570	939	1416	2211	3622	5172	8030	10132	12214	17952
8	428	642	1058	1594	2490	4079	5825	9043	11411	13756	20218
9	476	714	1177	1773	2770	4536	6478	10057	12690	15298	22484
10	523	786	1295	1952	3049	4994	7131	11071	13970	16840	24751
11	572	857	1414	2131	3328	5451	7784	12084	15249	18382	27017
12	620	929	1533	2310	3607	5909	8437	13098	16528	19924	29283
13	668	1002	1652	2488	3886	6366	9090	14112	17807	21466	31549
14	715	1073	1770	2667	4165	6823	9743	15125	19086	23008	33815
15	763	1145	1889	2846	4444	7280	10396	16139	20365	24550	36082
16	811	1217	2007	3025	4724	7738	11049	17153	21644	26092	38348
17	860	1289	2126	3203	5003	8195	11702	18167	22923	27634	40614
18	907	1361	2244	3382	5282	8652	12355	19180	24202	29176	42881
19	955	1433	2363	3561	5561	9110	13008	20194	25481	30718	45147
20	1003	1505	2482	3739	5840	9567	13661	21208	26761	32260	47413
21	1051	1577	2600	3918	6120	10024	14314	22221	28040	33802	49679
22	1099	1649	2719	4097	6398	10481	14967	23235	29319	35344	51946
23	1147	1721	2838	4276	6678	10939	15620	24249	30598	36886	54212
24	1195	1793	2957	4455	6957	11396	16273	25262	31877	38428	56478
25	1243	1865	3075	4634	7236	11853	16926	26276	33156	39970	58744
26	1291	1937	3194	4812	7515	12310	17579	27290	34435	41512	61011
27	1339	2009	3312	4991	7795	12768	18232	28304	35714	43053	63277
28	1387	2081	3431	5170	8074	13225	18885	29317	36993	44596	65543
29	1435	2153	3549	5348	8353	13682	19538	30331	38273	46137	67810
30	1483	2224	3668	5527	8632	14140	20191	31345	39552	47680	70076
31	1531	2297	3787	5706	8911	14597	20844	32358	40831	49221	72342
32	1579	2368	3905	5885	9190	15054	21497	33372	42110	50763	74608
33	1627	2440	4024	6063	9469	15511	22150	34386	43389	52306	76875
34	1675	2512	4143	6242	9749	15969	22803	35399	44668	53847	79141
35	1723	2584	4262	6421	10028	16426	23456	36413	45947	55390	81407
36	1771	2656	4380	6600	10307	16883	24109	37427	47226	56931	83673
37	1819	2728	4499	6779	10586	17341	24762	38440	48505	58473	85940
38	1867	2800	4617	6957	10865	17798	25415	39454	49784	60015	88206
39	1915	2872	4736	7136	11144	18255	26068	40468	51064	61557	90472
40	1963	2944	4854	7315	11423	18712	26721	41482	52343	63099	92739
41	2011	3016	4973	7493	11703	19170	27374	42495	53622	64641	95005
42	2058	3088	5092	7672	11982	19627	28027	43509	54901	66183	97271
43	2107	3160	5211	7851	12261	20084	28680	44523	56180	67725	99537
44	2155	3232	5329	8030	12540	20542	29333	45536	57459	69267	101803
45	2203	3304	5448	8208	12820	20999	29986	46550	58738	70809	104070
46	2250	3376	5567	8387	13099	21456	30639	47564	60017	72351	106336
47	2298	3448	5685	8566	13378	21913	31292	48577	61296	73893	108602
48	2346	3519	5804	8745	13657	22371	31945	49591	62575	75435	110868
49	2395	3592	5922	8924	13936	22828	32598	50605	63855	76977	113135
50	2442	3664	6041	9102	14215	23285	33251	51618	65134	78519	115401
52	2538	3808	6278	9460	14774	24200	34557	53646	67692	81603	119934
54	2634	3951	6516	9817	15332	25114	35863	55674	70250	84687	124466
56	2730	4095	6753	10175	15890	26029	37168	57701	72809	87771	128999
58	2826	4239	6990	10532	16448	26943	38475	59728	75367	90855	133531
60	2922	4383	7227	10890	17007	27858	39781	61755	77925	93939	138064
62	3018	4527	7464	11247	17565	28773	41087	63783	80483	97022	142596
64	3114	4671	7702	11605	18124	29687	42393	65810	83041	-	-
66	3210	4815	7939	11962	18682	30602	43698	67838	85600	-	-
68	3306	4959	8177	12320	19240	31516	45004	69865	88158	-	-
70	3402	5103	8414	12677	19799	32431	46310	71892	90716	-	-
72	3498	5246	8651	13035	20357	33345	47616	73920	93274	-	-
74	3593	5391	8888	13393	20915	34260	48923	75947	95833	-	-
76	3690	5534	9126	13750	21473	35174	50228	77975	98391	-	-
78	3785	5678	9363	14107	22032	36089	51534	80002	100949	-	-
80	3881	5822	9600	14465	22590	37004	52840	82029	103507	-	-
85	4121	6182	10193	15359	23986	39290	56105	87098	109903	-	-
90	4361	6541	10787	16252	25382	41577	59370	92167	116298	-	-
95	4601	6902	11379	17146	26778	43863	62635	97235	122694	-	-
100	4841	7261	11973	18040	28174	46149	65900	102303	129090	-	-
103	4985	7477	12329	18576	29011	47521	67859	105345	132927	-	-

General Notes:

1. The 6400 Series is also Section VIII certified for air & gas service, for Air capacities at 10% overpressure contact factory.

Dimensions & Weights

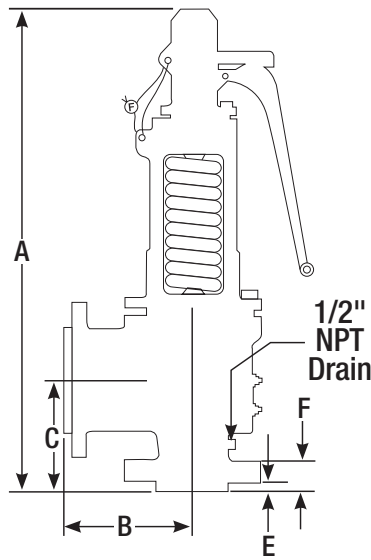

Valve Size Inlet x Outlet	Type Number	ANSI Flange Class		US Standard Dimensions (inches)					Approx. Weight Lbs.	Metric Dimensions (millimeters)					Approx. Weight kg.
		Inlet RF	Outlet RF	A	B	C	E	F		A	B	C	E	F	
1 x 2	64DA12-170	300#	150#	18 7/8	4 1/2	4 1/8	1/2	1 1/4	42	480	115	105	13	32	20
	64DA13-170	600#			4 1/2	4 1/8	1/2	1 1/4	42		115	105	13	32	20
	64DA14-170	900#			4 1/2	4 1/8	1/2	1 11/16	48		115	105	13	43	22
	64DA15-170	1500#			4 1/2	4 1/8	1/2	1 11/16	48		115	105	13	43	22
1 x 2	64EA12-170	300#	150#	18 7/8	4 1/2	4 1/8	1/2	1 1/4	42	480	115	105	13	32	20
	64EA13-170	600#			4 1/2	4 1/8	1/2	1 1/4	42		115	105	13	32	20
	64EA14-170	900#			4 1/2	4 1/8	1/2	1 11/16	48		115	105	13	43	22
	64EA15-170	1500#			4 1/2	4 1/8	1/2	1 11/16	48		115	105	13	43	22
1 1/2 x 2	64FA12-170	300#	150#	22 3/4	6	4 7/8	11/16	1 5/8	50	578	153	124	18	42	23
	64FA13-170	600#			6	4 7/8	11/16	1 5/8	50		153	124	18	42	23
	64FA14-170	900#			6	4 7/8	11/16	2	60		153	124	18	51	28
	64FA15-170	1500#			6	4 7/8	11/16	2	60		153	124	18	51	28
1 1/2 x 3	64GA12-170	300#	150#	22 7/8	5 1/8	5 1/8	11/16	1 11/16	60	582	131	131	18	43	28
	64GA13-170	600#			5 1/8	5 1/8	11/16	1 11/16	60		131	131	18	43	28
	64GA14-170	900#			5 1/8	5 1/8	11/16	2	60		131	131	18	51	28
	64GA15-170	1500#			5 1/8	5 1/8	11/16	2	85		131	131	18	51	39
1 1/2 x 3	64HA12-170	300#	150#	22 7/8	5 1/8	5 1/8	11/16	1 11/16	70	582	131	131	18	43	32
	64HA13-170	600#			5 1/8	5 1/8	11/16	1 11/16	70		131	131	18	43	32
	64HA14-170	900#			5 1/8	5 1/8	11/16	2	70		131	131	18	51	32
	64HA15-170	1500#			5 1/8	5 1/8	11/16	2	85		131	131	18	51	39
2 x 3	64JA12-170	300#	150#	23 7/8	6 3/8	6 1/16	11/16	1 11/16	70	607	162	154	18	43	32
	64JA13-170	600#			6 3/8	6 1/16	11/16	1 11/16	70		162	154	18	43	32
2 1/2 x 4	64JA14-170	900#	150#	33 3/8	6 3/4	6 1/8	11/16	2 3/8	70	848	172	156	18	61	32
	64JA15-170	1500#			6 3/4	6 1/8	11/16	2 3/8	85		172	156	18	61	39
2 1/2 x 4	64KA12-170	300#	150#	33 1/2	6 3/4	6 1/8	11/16	1 15/16	150	851	172	156	18	50	69
	64KA13-170	600#			6 3/4	6 1/8	11/16	1 15/16	150		172	156	18	50	69
	64KA14-170	900#			6 3/4	6 1/8	11/16	2 3/8	150		172	156	18	61	69
	64KA15-170	1500#			6 3/4	6 1/8	11/16	2 3/8	175		172	156	18	61	80
3 x 6	64LA12-170	300#	150#	36 5/8	8 1/2	7 13/16	11/16	2	230	931	216	199	18	51	105
	64LA13-170	600#			8 1/2	7 13/16	11/16	2	230		216	199	18	51	105
	64LA14-170	900#			8 1/2	7 13/16	11/16	2 1/4	230		216	199	18	58	105
	64LA15-170	1500#			8 1/2	7 13/16	11/16	2 11/16	250		216	199	18	69	114
3 x 6	64MA12-170	300#	150#	36 5/8	8 1/2	7 13/16	11/16	2	230	931	216	199	18	51	105
	64MA13-170	600#			8 1/2	7 13/16	11/16	2	230		216	199	18	51	105
	64MA14-170	900#			8 1/2	7 13/16	11/16	2 1/4	230		216	199	18	58	105
	64MA15-170	1500#			8 1/2	7 13/16	11/16	2 11/16	250		216	199	18	69	114
4 x 6	64NA12-170	300#	150#	42 3/8	10	8 7/8	11/16	2	230	1077	254	226	18	51	105
	64NA13-170	600#			10	8 7/8	11/16	2 1/4	250		254	226	18	58	114
	64NA14-170	900#			10	8 7/8	11/16	2 1/2	250		254	226	18	64	114
4 x 6	64PA12-170	300#	150#	42 3/8	10	8 7/8	11/16	2	230	1077	254	226	18	51	105
	64PA13-170	600#			10	8 7/8	11/16	2 1/4	250		254	226	18	58	114
	64PA14-170	900#			10	8 7/8	11/16	2 1/2	250		254	226	18	64	114

General Notes

1. Tolerances for the B and C center-to-face dimensions are ± 1/16 inch for valve inlet sizes up to and including 4 inch and ± 1/8 inch for valve inlet sizes larger than 4 inch.
2. Above dimensions also apply to the 6600 series with closed bonnet.

Conversion Factors

To find desired value, multiply "Given" value by factor below

Pressure Conversion				
Given	psi	kPa	Bar	kg/cm ²
psi	1	6.8948	0.0689	0.0703
kPa	0.145	1	0.01	0.0102
Bar	14.504	100	1	1.0197
kg/cm ²	14.223	97.905	0.9	1

Liquid Flow Rate Conversion				
Given	gpm	bbl/day	l/min	m ³ /hr
gpm	1	34.29	3.785	0.2271
bbl/day	0.02917	1	0.1104	0.006624
l/min	0.2642	9.057	1	0.06
m ³ /hr	4.403	151	16.667	1

Mass Conversion				
Given	lb	tons	kg	tonnes
lb	1	0.0005	0.4536	0.00045
tons	2000	1	907.18	0.90718
kg	2.2046	0.0011	1	0.001
tonnes	2204.6	1.102	1000	1

Viscosity – Absolute or Dynamic		
To Convert From	To	Multiply By
Centipoise	lbf-sec/ft. ²	0.000208854
Centipoise	kg-sec/meter ²	0.000102
Lbf-sec/sq. ft.	Pascal-sec	47.8803
Pascal sec.	Centipoise	1000
Poise (gm/cm-sec)	Centipoise	100

Viscosity – Kinematic		
To Convert From	To	Multiply By
Centistokes	Stokes	0.01
Centistokes	sq. meters/sec	0.000001
Square Feet/Sec.	Centistokes	92903.04
Square Feet/Sec.	Square meters/sec	0.092903

Viscosity – Absolute to Kinematic		
To Convert From	To	Multiply By
Centipoise	Centistokes	1/density (g/cm ³)

Volume Conversion				
Given	ft ³	m ³	gal	liter
ft ³	1	0.02832	7.481	28.32
m ³	35.31	1	264.2	1000
gal	0.1337	0.00379	1	3.785
liter	0.03532	0.001	0.2642	1

Density Conversion				
Given	lb/ft ³	kg/m ³	g/cm ³	lb/gal
lb/ft ³	1	16.018	0.016	0.1337
kg/m ³	0.0624	1	0.001	0.0083
g/cm ³	62.428	1000	1	8.345
lb/gal	7.481	119.83	0.1198	1

Area Conversion				
Given	in ²	ft ²	mm ²	cm ²
in ²	1	0.00694	645.16	6.4516
ft ²	144	1	92903	929.03
mm ²	0.00155	1.08E-05	1	0.01
cm ²	0.155	0.0011	100	1

Temperature Conversion	
Fahrenheit (F) =	(1.8 x C) + 32
Celsius (C) =	0.555 x (F - 32)
Rankin (R) =	F + 459.67
Kelvin (K) =	C + 273.15

Length Conversion				
Given	ft	in	mm	m
ft	1	12	304.8	0.3048
in	0.0833	1	25.4	0.0254
mm	0.0033	0.0394	1	0.001
m	3.281	39.37	1000	1

Miscellaneous Conversions		
From	To	Multiply By
Specific Gravity-Gas	Molecular Wt-Gas	28.97
Density-Liq	Specific Gravity-Liq	1/(p Water)

Farris Engineering Products

Process Pressure Relief Valves

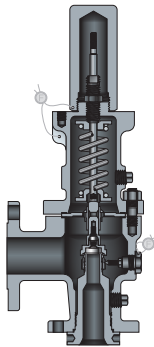

SERIES 2600/2600L

- ASME NB Certified: Air, Steam & Water
- Sizes: 1" x 2" to 20" x 24"
- Pressure Range: 15 psig to 6000 psig
- Temperature Range: -450°F to +1500°F
- Materials: Carbon Steel, Stainless Steel, Monel & Hastelloy C
- Options: Balanced Bellows, O-Ring Seat, Open Bonnet
- CE Approved

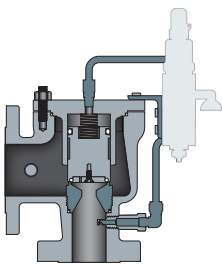

SERIES 3800 Pilot Operated

- ASME NB Certified: Air, Steam & Water
- Sizes: 1" x 2" to 12" x 16"
- Pressure Range: 15 psig to 6170 psig
- Temperature Range: -450°F to +500°F
- Materials: Carbon Steel, Stainless Steel, Monel & Hastelloy C
- Actuation: Snap and Modulating Controls
- Options: Field Test Connections, Reverse Flow Preventer, Remote Depressurizing & Auxiliary Filters
- CE Approved

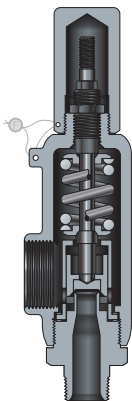

SERIES 2700

- ASME NB Certified: Air, Steam & Water
- Sizes: ½" x 1" to 1½" x 2½"
- Pressure Range: 15 psig to 6500 psig
- Temperature Range: -450°F to +750°F
- Materials: Carbon Steel, Stainless Steel, Monel & Hastelloy C
- Options: Balanced Design, O-Ring Seats, Flanged, Socket Weld, Welding Nipple, & Sanitary Connections
- CE Approved

*Other materials available upon request. Please consult the factory.

Steam Safety Valves

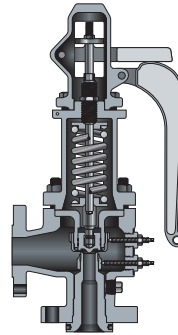

SERIES 4200

- ASME NB Section I & VIII Certified: Steam & Air
- Sizes 1¼" x 1½" to 6" x 8"
- Pressure Range: 15 psig to 1000 psig
- Temperature Range: -20°F to +1000°F
- Materials: Carbon Steel, Stainless Steel, Chrome-Moly
- Options: Test Gag
- CE Approved

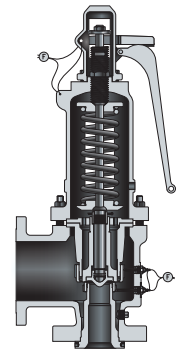

SERIES 6400/6600

- ASME NB Section I & VIII Certified: Steam & Air
- Sizes: 1" x 2" to 4" x 6"
- Pressure Range: 15 psig to 1500 psig
- Temperature Range: -20°F to +1000°F
- Materials: Carbon Steel, Stainless Steel, Chrome-Moly
- Options: Closed Bonnet (6600) & Test Gag



WARRANTY

Curtiss-Wright products have a warranty period of twelve months from first installation or eighteen months from delivery, whichever is sooner. All other warranty terms are as per Curtiss-Wright Industrial Standard Terms and Conditions, a copy which is available at www.cw-industrialgroup.com/About/Group-Policies/Terms-Conditions.aspx or contact your local representative.

Certifications, Compliances, and Approvals

- ASME V, UV, NV and NPT
- National Board Approval, NB
- NACE MR0175 / ISO15156
- ISO 9001:2015
- ISO 4126
- PED 2014/68/EU (European Pressure Equipment Directive)
- ATEX 2014/34/EU (European Potentially Explosive Atmospheres)
- CRN B51, N285.0 (Canadian Registration)
- CSQL (China Safety Quality License)
- Customs Union Certificates TR CU 010/2001 and TR CU 023/2013
- US Coast Guard
- API 526
- Nuclear Quality - 10 CFR 50 Appendix B, NCA-4000, NQA-1, N285.0 CSA N299.2/3/4"
- First Point Assessment Limited
- KGS (Korea Gas Safety)
- UKCA (United Kingdom Conformity Assessed)



**CURTISS -
WRIGHT** | **VALVES
DIVISION**

Curtiss-Wright, Valves Division

Headquarters: 10195 Brecksville Road, Brecksville, OH 44141 USA • Telephone: 440-838-7690 • <https://www.cw-valvegroup.com/en-gb/home>

Offices Worldwide: For a listing of our global sales network, visit our website at www.cw-valvegroup.com/farrisdistributors

While this information is presented in good faith and believed to be accurate, Curtiss-Wright Corporation, Valve Division does not guarantee satisfactory results from reliance on such information. Nothing contained herein is to be construed as a warranty or guarantee, expressed or implied, regarding the performance, merchantability, fitness or any other matter with respect to the products, nor as a recommendation to use any product or process in conflict with any patent. Curtiss-Wright Corporation, Farris Engineering reserves the right, without notice, to alter or improve the designs or specifications of the products described herein.

© Curtiss-Wright. All rights reserved. Specifications are subject to change without notice. All trademarks are property of their respective owners.